

MODEL NUMBER SYSTEM

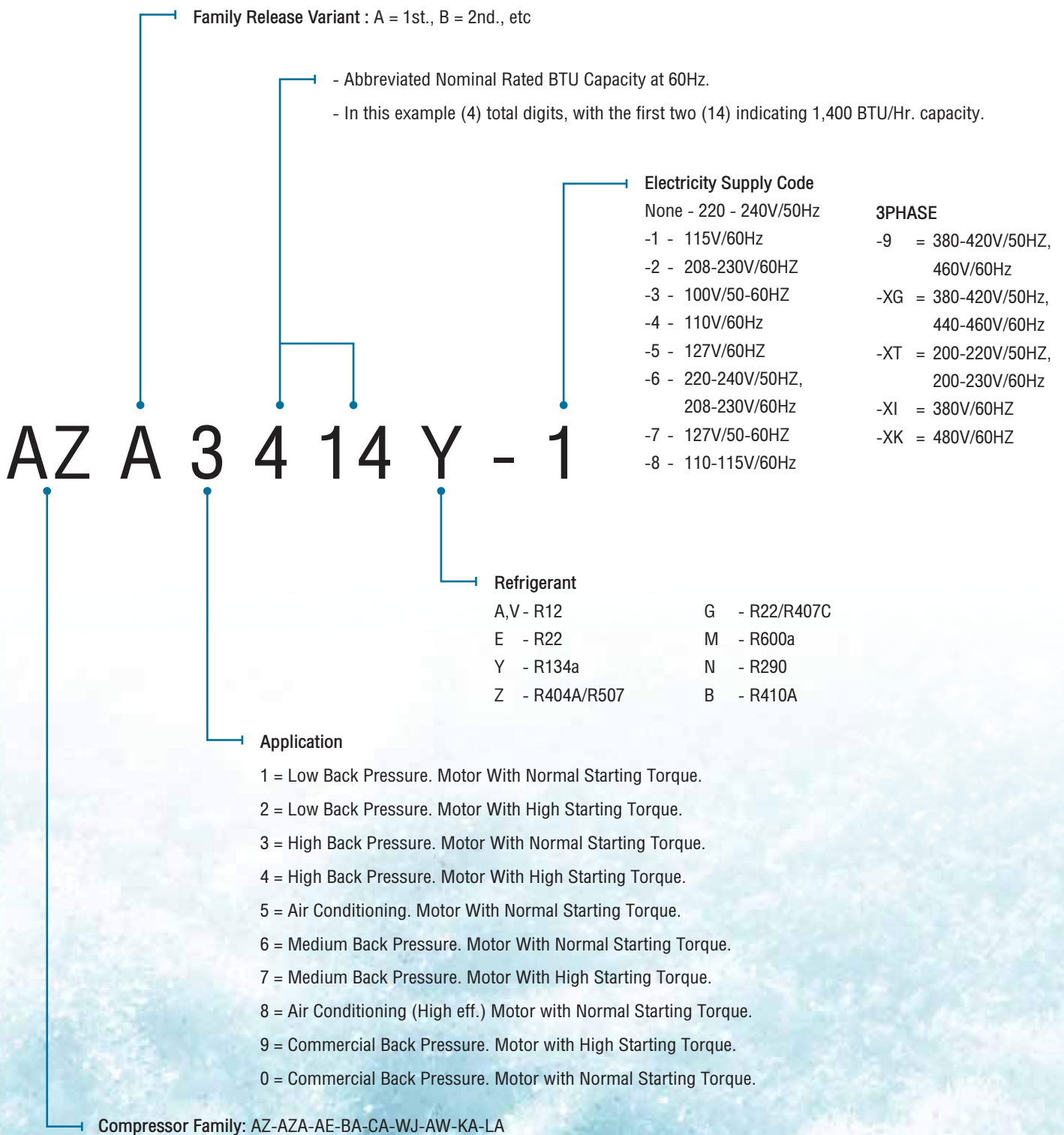

R290 LBP/MBP

Cooling Capacity (Watt)

Model	Power (HP)	Disp. (cc)	ASHRAE 46 / Evaporating Temperature											Motor Type	Start Cap. (μ F/VAC)	Run Cap. (μ F/VAC)	Height "A" (mm)	
			-20°C	-15°C	-10°C	-23.3°C				-5°C	-6.7°C	0°C	5°C					10°C
						Watt	BTU	Input	COP									
220-240V / 50Hz / 1 Ph.																		
BA2425N	2/3	14.14	471	523	584	636	2170	432	1.47	662	1382	1474	1579	1684	C.S.R	43-52/330	8/450	215
BA2428N	3/4	16.08	596	648	709	761	2597	570	1.34	787	1540	1632	1737	1842	C.S.R	43-52/330	20/440	215
115V / 60Hz / 1 Ph.																		
BA2425N-1	2/3	14.14	670	714	770	795	2713	530	1.5	821	1950	2042	2147	2252	C.S.R	108-130/250	15/450	215
BA2432N-1	5/6	18.00	880	924	980	1005	3429	720	1.4	1031	2010	2102	2207	2312	C.S.R	189-227/330	35/450	215

R290 LBP

Cooling Capacity (Watt)

Model	Power (HP)	Disp. (cc)	ASHRAE 32 / Evaporating Temperature									Motor Type	Start Cap. (μ F/VAC)	Run Cap. (μ F/VAC)	Height "A" (mm)	
			-35°C	-30°C	-25°C	-23.3°C				-20°C	-15°C					-10°C
						Watt	BTU	Input	COP							
220-240V/50Hz / 1 Ph.																
AZA2410N	1/4	5.59	138	179	235	260	887	186	1.40	325	429	541	R.S.I.R	36-43/330	—	178
AZA2413N	1/3	6.00	157	203	265	295	1007	210	1.40	369	487	630	C.S.I.R	36-43/330	—	178
AE2413N	1/3	6.92	187	231	287	312	1065	244	1.28	377	481	593	C.S.I.R	43-52/330	—	184
AE2415N	3/8	8.10	256	300	356	381	1300	283	1.35	446	550	662	C.S.I.R	43-52/331	—	184
AE2417N	1/2	9.42	236	305	400	445	1518	343	1.30	545	734	950	C.S.I.R	36-43/330	—	184
AE2425N	5/8	16.08	250	395	547	605	2064	445	1.36	720	900	1100	C.S.R	43-52/330	8/450	215
AE2428N	3/4	18.00	350	505	670	738	2518	628	1.18	860	1060	1250	C.S.R	88-106/330	20/440	215
CA2435N	7/8	22.30	444	609	785	854	2914	733	1.17	1010	1240	1482	C.S.R	88-106/330	20/440	215
WJ2450N	1-1/8	30.50	489	685	980	1105	3770	814	1.36	1389	1839	2353	C.S.R	145-174/330	25/440	264
115V/60Hz / 1 Ph.																
AE2415N-1	3/8	8.86	250	310	407	450	1535	330	1.36	550	750	1010	C.S.R	108-130/250	20/440	184
AE2417N-1	7/16	9.42	399	443	499	524	1788	430	1.22	589	693	805	C.S.I.R	108-130/330	—	196
AE2425N-1	3/5	16.08	300	460	640	710	2423	568	1.25	855	1080	1320	C.S.R	108-130/330	20/440	215
CA2432N-1	5/6	20.00	340	590	860	962	3282	780	1.23	1140	1420	1700	C.S.R	130-156/330	30/450	215
CA2435N-1	7/8	22.30	500	740	990	1084	3699	860	1.26	1260	1550	1850	C.S.R	130-156/330	30/450	215
WJ2440N-1	5/6	26.75	520	655	860	1000	3412	757	1.32	1380	2010	2650	C.S.R	243-292/250	40/425	264
WJ2450N-1	1-1/5	30.50	621	880	1235	1404	4790	1030	1.36	1755	2336	2988	C.S.R	243-292/250	40/425	264
208-230V/60Hz / 1 Ph.																
WJ2440N-2	5/6	26.75	520	655	860	1000	3412	757	1.32	1380	2010	2650	C.S.R	145-174/330	30/440	264
WJ2450N-2	1-1/5	30.50	621	880	1235	1407	4801	1080	1.30	1755	2336	2988	C.S.R	145-174/330	30/440	264
220-240V / 50Hz, 208-230V / 60Hz / 1 Ph.																
BA2417N-6	3/8	9.42	302	346	402	427	1457.0	309.0	1.38	492	596	708	C.S.R	43-52/370	8/450	184
			387	431	487	512	1747.0	347.0	1.48	577	681	793				
BA2425N-6	2/3	14.14	376	469	591	640	218.0	450.0	1.42	745	933	1157	C.S.R	43-52/330	8/450	215
			421	580	747	804	2743.0	512.0	1.57	917	1089	1260				

R290 MBP/CBP

Cooling Capacity (Watt)

Model	Power (HP)	Disp. (cc)	ASHRAE 46 / Evaporating Temperature											Motor Type	Start Cap. (μ F/VAC)	Run Cap. (μ F/VAC)	Height "A" (mm)	
			-20°C	-15°C	-10°C	-6.7°C				-5°C	0°C	5°C	7.2°C					10°C
						Watt	BTU	Input	COP									
220-240V / 50Hz / 1 Ph.																		
AE9415N	1/5	5.48	215	267	328	380	1297	253	1.50	406	498	590	650	690	C.S.I.R	36-43/250	—	188

R290 MBP/CBP

Cooling Capacity (Watt)																		
Model	Power (HP)	Disp. (cc)	ASHRAE 46 / Evaporating Temperature												Motor Type	Start Cap. (μ F/VAC)	Run Cap. (μ F/VAC)	Height "A" (mm)
			-20°C	-15°C	-10°C	-6.7°C				-5°C	0°C	5°C	7.2°C	10°C				
						Watt	BTU	Input	COP									
220-240V / 50Hz / 1 Ph.																		
AE9422N	1/4	7.57	314	389	476	540	1842	348	1.55	577	697	832	920	988	C.S.I.R	36-43/330	—	188
AE9426N	1/3	8.85	377	469	573	650	2218	433	1.50	705	843	1010	1090	1189	C.S.I.R	36-43/330	—	196
AE9435N	7/16	12.05	540	660	780	870	2968	483	2.30	925	1080	1245	1490	1595	C.S.R	36-43/329	8/450	212
AE9440N	1/2	14.14	610	757	925	1050	3583	583	1.80	1125	1360	1620	1760	1920	C.S.R	36-43/330	12/440	212
AE9445N	3/5	16.08	686	851	1040	1180	4026	715	1.65	1262	1512	1800	2000	2158	C.S.R	36-43/330	15/440	212
AE9450N	2/3	18.00	791	981	1199	1360	4640	777	1.75	1455	1743	2100	2300	2486	C.S.R	36-43/330	15/440	217
115V / 60Hz / 1 Ph.																		
AZA0410N-1	1/6	3.59	120	175	240	290	989	165	1.76	315	405	510	602	638	R.S.I.R	—	—	178
AZA0413N-1	1/8	4.00	175	230	290	340	1160	194	1.75	370	470	600	692	748	R.S.I.R	—	—	178
AZA0416N-1	1/5	5.00	285	340	400	450	1535	264	1.70	485	600	770	862	990	R.S.I.R	—	—	178
AE9422N-1	1/4	7.57	367	465	573	650	2218	410	1.59	705	845	1020	1120	1225	C.S.I.R	108-130/250	—	188
AE9426N-1	1/3	8.86	452	563	692	785	2678	523	1.50	842	1025	1230	1348	1486	C.S.R	108-130/250	20/440	196
AE9430N-1	3/8	10.26	550	680	850	980	550	550	1.78	1055	1265	1500	1700	1805	C.S.R	108-130/250	20/440	196
AE9440N-1	1/2	14.14	726	901	1090	1250	4265	740	1.69	1340	1620	1950	2140	2323	C.S.R	130-156/330	25/440	217
BA9445N-1	3/5	14.14	1302	1346	1402	1427	4869	748	1.91	2361	2453	2545	2335	2645	C.S.R	108-130/250	25/440	215
220-240V / 50Hz, 60Hz / 1 Ph.																		
AZA0413N-6	1/25	4.00	196	245	299	340	1160	194	1.75	366	450	560	652	678	R.S.I.R	—	—	178
			231	275	336	400	1365	229	1.75	431	545	660	752	775				
AZA9413N-6	1/6	4.00	165	217	278	330	1126	165	2.00	356	448	540	632	737	CSR	36-43/330	8/450	178
			235	287	348	400	1365	200	2.00	426	518	610	702	807				
AZA9417N-6	1/5	5.00	245	297	358	410	1399	205	2.00	436	528	620	712	817	CSR	36-43/330	10/440	178
			335	387	448	500	1706	250	2.00	526	618	710	802	907				
AZA9420N-6	1/4	6.00	350	402	463	515	1757	245	2.10	541	633	725	817	922	CSR	36-43/330	10/440	178
			446	498	559	611	2085	291	2.10	637	729	821	913	1018				
AE9426N-6	1/3	8.86	485	537	598	650	2218	419	1.55	676	768	860	952	1057	CSR	43-52/330	8/450	196
			617	669	730	782	2668	444	1.76	808	900	992	1084	1189				
AE9430N-6	1/3	10.26	635	687	748	800	2730	400	2.00	826	918	1010	1102	1207	CSR	43-52/330	15/440	197
			835	887	948	1000	3412	454	2.20	1026	1118	1210	1303	1408				
AE9435N-6	3/8	12.04	705	757	818	870	2968	435	2.00	896	988	1080	1172	1277	CSR	43-52/330	15/440	212
			935	987	1048	1100	3753	500	2.20	1126	1218	1310	1402	1507				
AE9440N-6	7/16	14.14	885	937	998	1050	3583	525	2.00	1076	1168	1260	1352	1457	CSR	43-52/330	40/370	212
			1135	1187	1248	1300	4436	590	2.20	1326	1418	1510	1602	1707				
BA9445N	5/8	14.14	1023	1075	1136	1188	4053	645	1.84	1214	1306	1398	1975	2259	C.S.R	36-43/330	10/450	202
208-230V / 60Hz / 1 Ph.																		
AE9422N-2	1/4	7.57	367	465	573	650	2218	410	1.59	695	835	1000	1120	1225	C.S.I.R	43-52/330	—	188
AE9426N-2	1/3	8.86	463	577	705	800	2730	490	1.63	856	1028	1235	1360	1468	C.S.I.R	43-52/330	—	196
AE9430N-2	3/8	10.26	550	7015	870	996	3398	585	1.70	1065	1265	1500	1753	1858	CSR	43-52/330	15/450	196
AE9435N-2	7/16	12.04	600	775	965	1087	3709	630	1.73	1170	1410	1650	1900	2005	CSR	43-52/330	15/450	212
AE9440N-2	1/2	14.14	744	940	1136	1290	4401	735	1.76	1381	1654	1980	2198	2362	C.S.R	43-52/330	15/440	212

R600a LBP

Cooling Capacity (watt)																
Model	Power (HP)	Disp. (cc)	ASHARE 32 / Evaporating Temperature									Motor Type	Start Cap. (μ F/VAC)	Run Cap. (μ F/VAC)	Height "A" (mm)	
			-35°C	-30°C	-25°C	-23.3°C				-20°C	-15°C					-10°C
						Watt	BTU	Input	COP							
220-240V/50Hz / 1 Ph.																
AZA1320M	1/20	3.80	29	38	50	55	188	42	1.31	66	87	114	R.S.C.R	—	3/450	168
AZA1327M	1/16	4.00	33	44	59	65	205	46	1.41	79	103	130	R.S.C.R	—	3/450	168

Cooling Capacity (watt)

Model	Power (HP)	Disp. (cc)	ASHARE 32 / Evaporating Temperature										Motor Type	Start Cap. (μ F/VAC)	Run Cap. (μ F/VAC)	Height "A" (mm)
			-35°C	-30°C	-25°C	-23.3°C				-20°C	-15°C	-10°C				
						Watt	BTU	Input	COP							
220-240V/50Hz / 1 Ph.																
AZA1330M	1/15	5.00	36	49	63	70	239	50	1.40	85	110	138	R.S.C.R	—	4/450	168
AZA1335M	1/15	5.60	46	60	78	85	290	67	1.27	99	125	155	R.S.C.R	—	4/450	172
AZA1340M	1/10	6.00	54	69	87	95	307	64	1.48	109	137	167	R.S.C.R	—	4/440	172
AE1340M	1/10	6.91	66	83	103	112	382	78	1.44	128	156	186	R.S.C.R	—	4/440	184
AE1350M	1/8	8.10	82	102	124	132	450	90	1.47	149	177	210	R.S.C.R	—	5/450	184
AE1360M	1/8	9.42	102	126	151	160	546	110	1.46	180	212	247	R.S.C.R	—	4/440	184
BA1390M	1/5	14.14	145	182	221	235	802	145	1.62	263	307	352	R.S.C.R	—	5/450	202
115V/60Hz / 1 Ph.																
AZA1320M-1	1/20	3.80	33	44	59	65	222	64	1.02	79	103	130	R.S.I.R.	—	—	159
AZA1327M-1	1/16	4.00	36	49	63	70	239	68	1.03	85	110	138	R.S.I.R.	—	—	168
AZA1330M-1	1/15	5.00	46	60	78	85	290	80	1.06	99	125	155	R.S.I.R.	—	—	168
AZA1340M-1	1/10	6.00	69	86	107	115	392	75	1.53	132	159	189	R.S.C.R	—	8/450	172
208-230V/60Hz / 1 Ph.																
AZA1340M-2	1/10	6.00	69	86	107	115	392	76	1.51	132	159	189	R.S.C.R	—	4/440	172
AE1360M-2	1/6	9.42	118	145	174	185	631	128	1.45	206	242	277	R.S.C.R	—	4/450	176
100V/50-60Hz / 1 Ph.																
AE1350M-3	1/8	8.10	80	100	122	130	444	102	1.27	148	176	208	R.S.I.R.	—	—	184
			94	116	141	150	512	115	1.30	169	200	234				

R134a LBP

Cooling Capacity (Watt)

Model	Power (HP)	Disp. (cc)	ASHRAE 32 / Evaporating Temperature										Motor Type	Start Cap. (μ F/VAC)	Run Cap. (μ F/VAC)	Height "A" (mm)
			-35°C	-30°C	-25°C	-23.3°C				-20°C	-15°C	-10°C				
						Watt	BTU	Input	COP							
220-240V/50Hz / 1 Ph.																
AZA1320Y	1/20	2.73	19	34	51	58	198	57	1.02	71	93	119	R.S.I.R	—	—	162
			19	34	51	58	198	52	1.12	71	93	119	R.S.C.R	—	4/450	159
AZA1327Y	1/15	3.28	26	49	72	81	276	83	0.98	98	128	166	R.S.I.R	—	—	168
			26	49	72	80	273	65	1.23	98	128	166	R.S.C.R	—	4/440	159
AZA1330Y	1/10	3.59	27	53	80	85	290	79	1.08	111	144	187	R.S.I.R	—	—	159
			27	53	80	85	290	79	1.08	111	144	187	R.S.C.R	—	4/440	168
AZA1335Y	1/10	3.80	32	57	86	96	328	82	1.17	118	154	195	R.S.I.R	—	—	168
			32	57	86	96	328	75	1.28	118	154	195	R.S.C.R	—	4/440	168
AZA1340Y	1/10	4.00	35	65	98	105	358	92	1.14	135	176	229	R.S.I.R	—	—	168
			35	65	98	110	375	80	1.38	135	176	229	R.S.C.R	—	4/440	168
AZA2340Y	1/10	4.00	35	65	98	110	375	92	1.20	135	176	229	C.S.I.R	36-43/330	—	168
AZA1350Y	1/8	5.00	38	77	119	134	457	103	1.30	166	220	281	R.S.I.R	—	—	168
			38	77	119	134	457	103	1.30	166	220	281	R.S.C.R	—	4/440	180
AZA2350Y	1/8	5.00	38	77	119	135	461	108	1.25	166	220	281	R.S.I.R	36-43/330	—	180
AZA1360Y	1/8	5.59	25	75	130	145	495	128	1.13	187	247	312	R.S.I.R	—	—	178
			25	75	130	145	495	105	1.38	187	247	312	R.S.C.R	—	4/440	180
AZA2360Y	1/8	5.59	25	75	130	145	495	128	1.13	187	247	312	C.S.I.R	36-43/330	—	178
AZA1370Y	1/6	6.00	39	94	151	165	563	137	1.20	217	285	364	R.S.I.R	—	—	178
			39	94	151	165	563	137	1.20	217	285	364	R.S.C.R	—	4/440	180
AZA2370Y	1/6	6.00	39	94	151	165	563	137	1.20	217	285	364	R.S.I.R	36-43/330	—	178

Cooling Capacity (Watt)

Model	Power (HP)	Disp. (cc)	ASHRAE 32 / Evaporating Temperature										Motor Type	Start Cap. (μF/VAC)	Run Cap. (μF/VAC)	Height "A" (mm)
			-35°C	-30°C	-25°C	-23.3°C				-20°C	-15°C	-10°C				
						Watt	BTU	Input	COP							
220-240V/50Hz / 1 Ph.																
AE1370Y	1/6	6.92	65	119	177	200	682	145	1.38	240	305	370	R.S.I.R	—	—	184
			65	119	177	200	682	134	1.49	240	305	370	R.S.C.R	—	4/440	184
AE2370Y	1/6	8.10	65	119	177	185	631	163	1.13	240	305	370	C.S.I.R	36~43/330	—	183
AE1390Y	1/5	9.42	115	163	214	252	860	192	1.31	290	388	485	R.S.I.R	—	—	189
			115	163	214	240	819	160	1.50	290	388	485	R.S.C.R	—	4/440	184
AE2390Y	1/5	9.42	115	163	214	237	809	205	1.16	290	338	485	C.S.I.R	36~43/330	—	202
AE2410Y	1/4	14.14	129	183	249	270	921	255	1.06	347	450	566	C.S.I.R	36~43/330	—	216
			129	183	249	270	921	210	1.29	347	450	566	C.S.R	36~43/330	8/450	184
AEA2410Y	1/4	12.04	130	181	244	270	921	226	1.19	323	416	520	C.S.I.R	36~43/330	—	216
AEA2413Y	1/3	14.14	166	227	302	330	1126	285	1.16	395	495	601	C.S.I.R	36~43/330	—	216
AEA2415Y	1/3	16.15	160	241	334	370	1262	280	1.32	437	545	658	C.S.R.	36~43/330	8/450	212
AE2417Y	3/8	18.00	166	240	352	400	1365	325	1.23	505	695	930	C.S.R	36~43/330	10/440	216
115V/60Hz / 1 Ph.																
AZA1320Y-1	1/15	2.73	23	45	69	77	263	77	1.00	94	124	160	R.S.I.R	—	—	162
AZA1327Y-1	1/15	3.28	40	58	84	92	314	84	1.10	115	152	198	R.S.I.R	—	—	168
AZA1330Y-1	1/10	3.59	41	67	99	110	375	97	1.13	135	176	223	R.S.I.R	—	—	168
AZA1335Y-1	1/10	3.80	40	68	102	112	382	106	1.06	141	186	239	R.S.I.R	—	—	168
AZA1340Y-1	1/10	4.00	52	80	111	126	430	120	1.05	152	200	260	R.S.I.R	—	—	168
AZA1350Y-1	1/8	5.00	45	85	132	148	505	140	1.06	187	246	312	R.S.I.R	—	—	172
AZA1360Y-1	1/8	5.59	49	102	162	180	614	156	1.15	230	303	385	R.S.I.R	—	—	178
AZA1370Y-1	1/6	6.00	57	110	172	195	665	170	1.15	241	320	410	R.S.I.R	—	—	178
208-230V/60Hz / 1 Ph.																
AZA1320Y-2	1/15	2.95	30	48	69	77	263	77	1.00	94	123	157	R.S.I.R	—	—	162
AZA1327Y-2	1/15	3.28	40	58	84	92	314	86	1.07	115	152	198	R.S.I.R	—	—	168
AZA1330Y-2	1/10	3.59	41	67	99	110	375	95	1.16	135	176	223	R.S.I.R	—	—	168
AZA1335Y-2	1/10	3.80	52	74	102	115	392	104	1.11	141	185	239	R.S.I.R	—	—	168
AZA1340Y-2	1/10	4.00	46	79	114	128	437	112	1.14	157	205	266	R.S.I.R	—	—	168
AZA1350Y-2	1/8	5.00	45	85	132	150	512	132	1.14	187	246	312	R.S.I.R	—	—	172
AZA1360Y-2	1/8	5.59	49	100	159	183	624	148	1.24	229	301	381	R.S.I.R	—	—	168
AE1370Y-2	1/6	8.10	65	124	187	210	717	184	1.14	258	335	424	R.S.I.R	—	—	189
AE1390Y-2	1/4	9.42	129	183	249	280	955	235	1.19	347	450	566	R.S.I.R	—	—	202
AE2390Y-2	1/4	9.42	129	183	249	280	955	236	1.19	347	450	566	C.S.I.R	36~43/330	—	202
AE2410Y-2	1/4	14.14	117	195	282	312	1065	307	1.02	385	500	630	C.S.I.R	36~43/330	—	216
AE2413Y-2	1/3	16.08	160	241	334	372	1269	349	1.07	452	596	751	C.S.R	36~43/330	8/450	216
100V/50-60Hz / 1 Ph.																
AE2360Y-3	1/6	6.92	68	109	156	175	597	155	1.13	213	278	356	C.S.R	36~43/250	15/440	189
			62	120	186	210	717	183	1.15	258	335	418	C.S.R	36~43/250	15/440	189
AE2370Y-3	1/5	8.10	97	135	187	208	710	180	1.16	255	337	433	C.S.R	36~43/250	15/440	189
			76	147	220	250	853	216	1.16	300	382	470	C.S.R	36~43/250	15/440	189
AE2390Y-3	1/4	9.42	82	144	212	240	819	196	1.22	292	384	485	C.S.R	108~130/250	15/440	189
			121	183	257	280	955	230	1.22	353	466	583	C.S.R	108~130/250	15/440	189
220-240V/50Hz, 208-230V/60Hz / 1 Ph.																
AZA1330Y-6	1/10	3.59	27	53	80	90	307	97	0.93	111	144	187	R.S.I.R	—	—	168
			40	66	98	110	375	105	1.05	137	180	229	R.S.I.R	—	—	168
AZA1335Y-6	1/10	3.80	32	57	86	96	328	100	0.96	118	154	195	R.S.I.R	—	—	168
			52	74	102	115	392	108	1.06	141	185	239	R.S.I.R	—	—	168

Cooling Capacity (Watt)

Model	Power (HP)	Disp. (cc)	ASHRAE 32 / Evaporating Temperature										Motor Type	Start Cap. (μ F/VAC)	Run Cap. (μ F/VAC)	Height "A" (mm)	
			-35°C	-30°C	-25°C	-23.3°C				-20°C	-15°C	-10°C					
						Watt	BTU	Input	COP.								
220-240V/50Hz, 208-230V/60Hz / 1 Ph.																	
AZA1350Y-6	1/8	5.00	38	77	119	134	457	109	1.23	166	220	281	R.S.I.R	—	—	178	
			45	85	132	150	512	125	1.20	187	246	312	R.S.I.R	—	—	178	
AZA1360Y-6	1/8	5.59	35	78	126	145	495	121	1.20	180	238	302	R.S.I.R	—	—	178	
			49	97	150	170	580	135	1.26	211	278	354	R.S.I.R	—	—	178	
AZA1370Y-6	1/6	6.00	40	90	145	165	563	155	1.06	207	275	345	R.S.I.R	—	—	178	
			57	110	172	195	665	160	1.22	241	320	410	R.S.I.R	—	—	178	
AZA1370Y-6	1/6	6.00	40	97	145	165	563	150	1.10	207	275	345	R.S.C.R	—	4/440	178	
			57	110	172	195	665	153	1.27	241	320	410	R.S.C.R	—	4/440	178	
AE1390Y-6	1/4	9.42	83	154	230	255	870	203	1.26	309	395	485	R.S.I.R	—	—	202	
			117	189	270	297	1013	236	1.26	362	463	572	R.S.I.R	—	—	202	

R134a MBP/CBP

Cooling Capacity (Watt)

Model	Power (HP)	Disp. (cc)	ASHRAE 46 / Evaporating Temperature											Motor Type	Start Cap. (μ F/VAC)	Run Cap. (μ F/VAC)	Height "A" (mm)	
			-20°C	-15°C	-10°C	-6.7°C				-5°C	0°C	5°C	7.2°C					10°C
						Watt	BTU	Input	COP									
220-240V/50Hz / 1 Ph.																		
AZA0349Y	1/15	2.73	50	86	124	150	512	110	1.36	165	207	251	343	448	R.S.I.R	—	—	162
AZA9349Y	1/15	2.73	50	86	124	150	512	110	1.36	165	207	251	343	448	C.S.I.R	36-43/330	—	162
AZA0387Y	1/10	3.80	85	130	180	215	734	143	1.50	236	293	356	448	553	R.S.I.R	—	—	168
AZA9387Y	1/10	3.80	85	130	180	215	734	143	1.50	236	293	356	448	553	C.S.I.R	36-43/330	—	168
AZA0411Y	1/8	5.00	143	192	245	285	972	178	1.60	308	380	458	550	655	R.S.I.R	—	—	178
AZA9411Y	1/8	5.00	143	192	245	285	972	178	1.60	308	380	458	550	655	C.S.I.R	36-43/330	—	178
AZA0413YK	1/6	6.00	105	191	280	336	1146	213	1.58	375	470	570	662	767	R.S.I.R	—	—	178
AZA9413Y	1/6	6.00	105	191	280	340	1160	213	1.60	375	470	570	662	767	R.S.I.R	—	—	178
AE6412Y	1/6	5.99	152	205	270	315	1075	193	1.63	345	436	540	632	737	R.S.I.R	—	—	189
AE7415Y	1/6	7.57	195	253	320	370	1262	250	1.48	400	504	648	740	845	C.S.I.R	36-43/330	—	188
AE9417Y	1/5	8.10	243	326	410	470	1604	261	1.80	502	588	680	820	925	C.S.R	36-43/330	8/450	184
AE9419Y	1/5	9.42	243	325	415	480	1368	330	1.45	512	610	707	902	1007	C.S.I.R	36-43/330	—	189
AE7423Y	1/4	12.04	255	365	486	574	1958	360	1.59	620	768	930	1022	1127	C.S.I.R	36-43/330	—	203
AE7426Y	1/4	14.14	295	415	550	640	2184	425	1.51	690	854	1037	1129	1234	C.S.I.R	36-43/330	—	216
AE7430Y	3/8	16.08	380	498	633	745	2542	455	1.64	805	1015	1265	1357	1462	C.S.R	36-43/330	8/450	216
AE9437Y	1/2	18.00	520	632	784	920	3139	532	1.73	987	1240	1570	1662	1767	C.S.R	36-43/330	10/440	216
BA9426Y	1/3	12.03	295	415	550	650	2218	351	1.85	710	880	1070	1170	1270	C.S.R	36-43/330	8/450	202
BA9430Y	3/8	14.14	400	521	661	760	2593	410	1.85	816	991	1195	1361	1466	C.S.R	36-43/330	12/440	215
CA9437Y	3/8	18.00	520	632	784	920	3139	510	1.80	987	1240	1570	1680	1785	C.S.R	36-43/330	10/440	215
CA9440Y	1/2	20.00	470	650	859	1000	3.412	588	1.70	1080	1334	1660	1830	1935	C.S.R	43-52/330	10/440	215
CA9445Y	1/2	22.30	540	730	942	1100	3753	667	1.65	1190	1490	1850	2000	2280	C.S.R	43-52/330	15/440	215
WJ9430YK	7/16	19.80	450	570	735	880	3003	490	1.80	970	1286	1700	1792	1897	C.S.R	88-106/330	15/440	264
WJ9440YK	1/2	21.55	420	609	847	1025	3497	560	1.83	1126	1441	1785	1877	1982	C.S.R	88-106/330	15/440	264
WJ9445YK	5/8	24.20	570	774	999	1170	3992	640	1.83	1273	1594	1990	1082	2287	C.S.R	88-106/330	20/440	264
WJ9450YK	5/8	26.75	640	891	1154	1348	4599	790	1.71	1456	1833	2280	2372	2477	C.S.R	88-106/330	15/440	264
WJ9460YK	3/4	30.50	790	1044	1353	1580	5391	870	1.82	1714	2146	2655	2747	2852	C.S.R	88-106/330	15/440	264
WJ9470Y	3/4	34.50	820	1084	1438	1720	5869	1010	1.70	1890	2441	3100	3297	3502	C.S.R	88-106/330	15/440	264

115V/60Hz / 1 Ph.

AZA0349Y-1	1/15	2.73	78	112	150	170	580	128	1.37	190	238	295	315	360	R.S.I.R	—	—	168
AZA0370Y-1	1/15	2.95	85	121	162	191	648	137	1.45	207	259	323	345	396	R.S.I.R	—	—	168
AZA0387Y-1	1/10	3.80	108	157	212	252	860	168	1.50	274	341	422	445	520	R.S.I.R	—	—	168
AZA9387Y-1	1/10	3.80	108	157	212	252	860	168	1.50	274	341	422	445	520	C.S.I.R	88-106/330	—	168
AZA0411Y-1	1/8	5.00	170	221	286	332	1133	218	1.52	365	456	550	590	651	R.S.I.R	—	—	178
AZA0413YK-1	1/6	6.00	205	266	339	399	1361	255	1.56	435	545	660	752	857	R.S.I.R	—	—	178

R134a MBP/CBP

Cooling Capacity (Watt)

Model	Power (HP)	Disp. (cc)	ASHRAE 46 / Evaporating Temperature											Motor Type	Start Cap. (µF/VAC)	Run Cap. (µF/VAC)	Height "A" (mm)	
			-20°C	-15°C	-10°C	-6.7°C				-5°C	0°C	5°C	7.2°C					10°C
						Watt	BTU	Input	COP									
115V/60Hz / 1 Ph.																		
AZA9413Y-1	1/6	6.00	200	264	330	384	1310	260	1.48	414	520	640	732	837	C.S.I.R	36-43/250	—	178
AE7423Y-1	1/4	12.04	310	427	569	674	2300	420	1.60	734	925	1150	1242	1391	C.S.R	130-156/330	15/440	212
AE7426Y-1	1/3	14.14	400	521	661	762	2600	487	1.56	816	991	1195	1287	1414	C.S.R	130-156/330	15/440	216
AE9437Y-1	1/2	18.00	540	680	850	986	3364	663	1.49	1080	1380	1700	1792	1897	C.S.R	130-156/330	25/440	216
CA9437Y-1	1/2	18.00	542	690	865	1010	3446	697	1.45	1100	1390	1710	1802	1910	C.S.I.R	130-156/330	—	215
CA9440Y-1	1/2	20.00	542	740	960	1120	3821	700	1.60	1215	1510	1850	1942	2050	C.S.R	130-156/330	25/440	215
CA9445Y-1	1/2	22.30	590	810	1040	1215	4146	860	1.41	1315	1630	2000	2105	2440	C.S.R	130-156/330	35/440	215
WJ9440YK-1	1/2	21.55	555	765	995	1180	4026	685	1.72	1283	1630	2020	2125	2470	C.S.R	216-259/250	25/440	264
WJ9445YK-1	5/8	24.20	390	710	1085	1380	4709	810	1.70	1537	2010	2510	2615	3000	C.S.R	216-259/250	30/440	264
WJ9460YK-1	3/4	30.50	700	1050	1490	1832	6251	1090	1.68	2020	2575	3220	3412	3920	C.S.R	216-259/250	30/440	264
208-230V/60Hz / 1 Ph.																		
AZA0387Y-2	1/10	3.80	108	157	212	252	860	164	1.54	274	341	422	514	619	R.S.I.R	—	—	168
AZA0413YK-2	1/6	6.00	200	264	333	390	1331	265	1.47	420	530	650	742	847	R.S.I.R	—	—	178
AZA9413Y-2	1/6	6.00	205	266	339	400	1365	265	1.51	435	545	660	752	857	C.S.I.R	36-43/330	—	178
AE0412Y-2	1/6	5.99	191	250	317	370	1262	230	1.61	400	500	620	712	817	R.S.I.R	—	—	189
AE7423Y-2	1/4	12.04	310	427	569	670	2286	438	1.53	731	925	1150	1242	1347	C.S.I.R	36-43/330	—	203
AE9423Y-2	1/4	12.04	310	427	573	682	2327	396	1.72	740	935	1150	1242	1347	C.S.R	36-43/330	8/450	203
AE7425Y-2	1/3	14.14	400	521	645	740	2525	497	1.49	792	957	1145	1242	1350	C.S.I.R	36-43/330	—	216
AE7430Y-2	3/8	16.08	410	579	749	866	2955	530	1.63	935	1128	1340	1432	1537	C.S.R	36-43/330	8/450	216
AE9437Y-2	3/8	18.00	530	675	860	1005	3429	635	1.58	1090	1380	1700	1792	1897	C.S.R	36-43/330	10/440	214
CA9437Y-2	3/8	18.00	542	690	865	1010	3446	608	1.66	1100	1390	1710	1820	1907	C.S.R	36-43/330	10/440	215
CA9440Y-2	1/2	20.00	542	761	986	1143	3900	700	1.63	1233	1518	1858	2070	2269	C.S.R	43-52/330	10/440	215
CA9445Y-2	1/2	22.30	603	830	1060	1235	4214	775	1.59	1333	1642	2008	2100	2360	C.S.R	43-52/330	15/440	215
WJ9440YK-2	1/2	21.55	545	760	990	1158	3951	680	1.70	1266	1590	2000	2092	2197	C.S.R	88-106/330	20/440	264
WJ9445YK-2	5/8	24.20	360	690	1075	1366	4661	767	1.78	1520	1970	2460	2197	2657	C.S.R	108-130/330	20/440	264
WJ9450Y-2	2/3	26.75	680	980	1330	1612	5500	850	1.90	1790	2400	3100	3192	3297	C.S.R	108-130/330	15/425	264
WJ9460YK-2	3/4	30.50	690	1030	1480	1800	6142	1025	1.76	1990	2530	3170	3262	3467	C.S.R	108-130/330	15/440	264

220-240V/50Hz, 208-230V/60Hz / 1 Ph.

AZA9387Y-6	1/10	3.80	85	130	180	215	734	143	1.50	236	293	356	448	553	C.S.I.R	36-43/330	—	168
			112	160	216	258	880	165	1.56	280	355	437	529	634				
AZA0411Y-6	1/8	5.00	143	192	245	285	972	178	1.60	308	380	458	550	655	R.S.I.R	—	—	178
			160	215	278	325	1109	203	1.60	355	443	542	634	739				
AZA9411Y-6	1/8	5.00	143	192	245	285	972	178	1.60	308	380	458	550	655	C.S.I.R	36-43/330	—	178
			160	215	278	325	1109	203	1.60	355	443	542	634	739				
AE7415Y-6	1/5	7.57	193	247	214	366	1249	260	1.41	395	502	644	736	841	C.S.I.R	36-43/330	—	188
			220	288	363	425	1450	283	1.50	466	595	750	842	947				
AE7423Y-6	1/4	12.04	255	365	486	574	1958	361	1.59	620	768	930	1022	1127	C.S.R	36-43/330	4/440	203
			310	427	569	670	2286	438	1.53	731	925	1150	1242	1347				
AE7430Y-6	1/3	16.08	380	490	615	722	2463	450	1.60	785	1010	1260	1352	1460	C.S.R	36-43/330	8/450	216
			410	579	749	866	2955	530	1.63	935	1128	1340	1432	1537				
CA9445Y-6	5/8	22.30	540	730	942	1100	3753	692	1.59	1190	1490	1850	1942	2050	C.S.R	43-52/330	15/440	215
			603	830	1060	1235	4214	775	1.59	1333	1642	2008	2100	2205				

R134a HBP

Cooling Capacity (Watt)

Model	Power (HP)	Disp. (cc)	ASHRAE 46 / Evaporating Temperature								Motor Type	Start Cap. (µF/VAC)	Run Cap. (µF/VAC)	Height "A" (mm)	
			-10°C	-5°C	0°C	5°C	+7.2°C								+10°C
							Watt	BTU	Input	COP					
220-240V/50Hz / 1 Ph.															
AZA3414Y	1/8	3.80	176	228	285	346	375	1280	175	2.14	417	R.S.I.R	—	—	168

Cooling Capacity (Watt)

Model	Power (HP)	Disp. (cc)	ASHRAE 46 / Evaporating Temperature									Motor Type	Start Cap. (μ F/VAC)	Run Cap. (μ F/VAC)	Height "A" (mm)
			-10°C	-5°C	0°C	5°C	+7.2°C				+10°C				
							Watt	BTU	Input	COP					
220-240V/50Hz / 1 Ph.															
AZA3417Y	1/6	5.00	200	280	365	475	500	1706	233	2.15	555	R.S.I.R	—	—	168
AZA4417Y	1/6	5.00	200	280	365	457	500	1706	233	2.15	555	C.S.I.R	36~43/330	—	168
AZA3423Y	1/5	5.59	246	342	440	540	586	1999	257	2.28	642	R.S.I.R	—	—	168
AZA3425Y	1/5	6.00	265	365	470	580	630	2150	285	2.21	700	R.S.I.R	—	—	178
AZA4425Y	1/5	6.00	265	365	470	580	630	2150	300	2.10	700	C.S.I.R	36~43/330	—	178
AE3425Y	1/5	7.57	287	385	505	655	730	2491	342	2.13	845	R.S.I.R	—	—	189
AE4425Y	1/5	7.57	287	383	494	630	700	2388	327	2.14	794	C.S.I.R	36~43/330	—	183
AE3430Y	1/4	8.86	358	464	595	760	850	2900	395	2.15	990	R.S.I.R	—	—	189
AE4430Y	1/4	8.86	355	460	590	738	820	2798	390	2.10	940	C.S.I.R	36~43/330	—	176
			355	460	590	738	820	2798	340	2.41	940	C.S.R	36~43/330	8/450	189
AE3435Y	1/4	9.42	395	500	625	800	892	3044	427	2.09	1020	R.S.I.R	—	—	189
AE4435Y	1/4	9.42	501	605	718	840	902	3078	440	2.05	980	C.S.I.R	36~43/330	—	189
			501	605	718	840	900	3071	375	2.40	980	C.S.R	36~43/330	8/450	189
AE4440Y	1/3	12.04	494	635	800	985	1075	3668	505	2.13	1195	C.S.I.R	36~43/330	—	202
			494	635	800	985	1075	3668	420	2.56	1195	C.S.R	36~43/330	8/450	202
AE4448Y	3/8	14.14	573	720	895	1095	1190	4060	575	2.07	1322	C.S.I.R	36~43/330	—	212
			567	725	906	1120	1220	4163	520	2.35	1359	C.S.R	36~43/330	12/440	212
AE4459Y	1/2	16.08	617	784	1011	1300	1450	4947	615	2.36	1651	C.S.R	43~52/330	15/440	216
AW4495YK	3/4	30.50	837	1135	1530	2070	2380	8121	850	2.80	2850	C.S.R	88~106/330	20/440	289
AW4513YK	1-1/4	35.60	1071	1470	2000	2680	3090	10543	1050	2.94	3700	C.S.R	88~106/330	30/440	289
AW4514YK	1-1/4	37.50	1113	1580	2150	2930	3334	11376	1104	3.02	3980	C.S.R	88~106/330	35/440	324
AW4515YK	1-1/5	39.60	1239	1700	2300	3060	3526	12031	1190	2.96	4200	C.S.R	88~106/330	35/440	324
AW4517YK	1-1/2	48.40	1600	2138	2860	3775	4298	14665	1487	2.89	5100	C.S.R	108~130/330	20/440	324
115V/60Hz / 1 Ph.															
AZA3414Y-1	1/8	3.80	190	252	324	405	445	1518	220	2.02	503	R.S.I.R	—	—	168
AZA4414Y-1	1/8	3.80	190	252	324	405	445	1518	220	2.02	503	C.S.I.R	88~106/330	—	168
AE3417Y-1	1/6	5.68	276	350	436	535	586	1999	288	2.03	654	R.S.I.R	—	—	189
AE3425Y-1	1/5	7.57	360	469	589	730	802	2736	401	2.00	896	R.S.I.R	—	—	172
AE4425Y-1	1/5	7.57	373	475	600	745	820	2798	419	1.96	930	C.S.I.R	108~130/250	—	189
AE4430Y-1	1/4	8.86	466	585	724	883	965	3293	432	2.23	1080	C.S.R	108~130/250	30/440	189
AE4440Y-1	1/3	12.04	500	640	815	1045	1174	4006	591	1.99	1350	C.S.R	108~130/250	20/440	203
AE4448Y-1	3/8	14.14	637	810	1025	1300	1456	4968	682	2.13	1688	C.S.R	108~130/250	20/440	216
AE4459Y-1	1/2	16.08	779	922	1160	1500	1700	5800	850	2.00	2000	C.S.R	130~156/330	25/440	216
208-230V/60Hz / 1 Ph.															
AZA3414Y-2	1/8	3.80	190	252	324	405	445	1518	215	2.07	503	R.S.I.R	—	—	168
AE3417Y-2	1/6	5.68	262	336	422	520	570	1945	295	1.93	630	R.S.I.R	—	—	189
AE3425Y-2	1/5	7.57	380	480	598	740	810	2764	392	2.07	920	R.S.I.R	—	—	189
AE4425Y-2	1/5	7.57	377	476	592	732	807	2753	390	2.07	915	C.S.I.R	36~43/330	—	189
AE3430Y-2	1/4	8.86	454	570	705	860	940	3207	460	2.04	1052	R.S.I.R	—	—	189
AE4430Y-2	1/4	8.86	454	570	705	860	940	3207	475	1.98	1052	C.S.I.R	36~43/330	—	201
			460	582	722	886	973	3320	436	2.23	1094	C.S.R	36~43/330	8/450	189

Cooling Capacity (Watt)

Model	Power (HP)	Disp. (cc)	ASHRAE 46 / Evaporating Temperature								Motor Type	Start Cap. (μ F/VAC)	Run Cap. (μ F/VAC)	Height "A" (mm)	
			-10°C	-5°C	0°C	5°C	+7.2°C								+10°C
							Watt	BTU	Input	COP					

208-230V/60Hz / 1 Ph.

AE4440Y-2	1/3	12.05	590	760	945	1140	1230	4197	610	2.02	1360	C.S.I.R	36~43/330	—	216
			609	777	965	1180	1270	4333	560	2.27	1433				C.S.R
AE4448Y-2	3/8	14.14	698	880	1082	1300	1402	4784	627	2.24	1540	C.S.R	36~43/330	—	212
AE4459Y-2	1/2	16.08	830	1035	1260	1515	1645	5613	774	2.13	1830	C.S.R	36~43/330	—	212
AW4495YK-2	4/5	30.50	1000	1470	2000	2590	2925	9980	1075	2.72	3400	C.S.R	130~156/330	—	289
AW4513YK-2	1-1/4	35.60	1253	1750	2340	3140	3640	12420	1304	2.79	4400	C.S.R	108~130/330	—	289
AW4517YK-2	1-1/2	48.40	1750	2500	3360	4430	5000	17060	1760	2.84	5800	C.S.R	130~156/330	—	324

100V/50-60Hz / 1 Ph.

AE4425Y-3	1/5	7.57	287	383	494	630	702	2395	356	1.97	794	C.S.I.R	108~130/250	—	189
			382	484	610	753	830	2832	393	2.11	940				
AE4430Y-3	1/4	8.86	358	464	595	745	820	2798	412	1.99	925	C.S.I.R	108~130/250	—	189
			458	584	720	868	940	3207	475	1.98	1035				
AE4440Y-3	1/3	12.04	494	635	800	985	1075	3668	560	1.92	1195	C.S.R	130~156/330	—	202
			639	801	970	1155	1245	4248	620	2.01	1370				
AE4448Y-3	3/8	14.14	659	813	992	1185	1280	4367	570	2.25	1410	C.S.R	130~156/330	—	216
			677	830	1025	1280	1430	4879	695	2.06	1676				

220-240V/50Hz, 208-230V/60Hz / 1 Ph.

AZA3417Y-6	1/6	5.00	200	280	365	457	500	1706	233	2.15	555	R.S.I.R	—	—	178
			240	319	418	537	600	2047	293	2.05	685	R.S.I.R			
AZA4417Y-6	1/6	5.00	200	280	365	457	500	1706	233	2.15	555	C.S.I.R	36~43/330	—	178
			240	319	418	537	600	2047	293	2.05	685	C.S.I.R			
AE3425Y-6	1/5	7.57	291	390	502	637	710	2423	343	2.07	810	R.S.I.R	—	—	183
			388	488	613	760	835	2849	396	2.11	933	R.S.I.R			
AE4425Y-6	1/5	7.57	287	383	494	630	700	2388	327	2.14	794	C.S.I.R	36~43/330	—	183
			388	488	605	745	821	2801	405	2.03	933	C.S.I.R			
AE4430Y-6	1/4	8.86	360	456	570	710	790	2695	320	2.47	906	C.S.R	36~43/330	—	183
			466	590	728	880	960	3276	390	2.46	1065	C.S.R			
AE4435Y-6	1/3	9.42	501	605	718	840	900	3071	370	2.43	980	C.S.R	36~43/330	—	183
			451	596	765	955	1050	3583	435	2.41	1188	C.S.R			
AE4440Y-6	1/3	12.04	494	635	800	985	1075	3668	456	2.36	1195	C.S.R	36~43/330	—	202
			648	810	987	1,180	1277	4357	550	2.32	1415	C.S.R			
AE4448Y-6	7/16	14.14	656	820	998	1,200	1304	4449	574	2.27	1460	C.S.R	36~43/330	—	216
			698	870	1,070	1,290	1401	4780	627	2.23	1569	C.S.R			
AE4459Y-6	1/2	16.08	617	784	1,011	1,290	1450	4947	615	2.36	1651	C.S.R	43~52/330	—	216
			830	1,035	1,260	1,520	1650	5630	750	2.20	1830	C.S.R			

380-420V/50Hz, 440-460V/60Hz / 3 Ph.

WJ4512YXG	1	34.50	1214	1655	2250	3000	3476	3476	1350	2.57	4263	3 Ph.	—	—	264
			1433	1950	2650	3535	4050	4050	1650	2.45	5000				
AW4520YXG	1-2/3	53.50	1967	2588	3488	4630	5352	5352	1575	3.40	6700	3 Ph.	—	—	324
			2292	3040	4063	5420	6234	6234	1850	3.37	7900				
AW4528YXG	2-1/3	71.00	2498	3370	4450	5900	6800	6800	2255	3.02	8600	3 Ph.	—	—	324
			3003	4050	5350	7100	8200	8200	2750	2.98	10000				

Cooling Capacity (watt)

Model	Power (HP)	Disp. (cc)	ASHRAE 32 / Evaporating Temperature										Motor Type	Start Cap. (μ F/VAC)	Run Cap. (μ F/VAC)	Height "A" (mm)
			-35°C	-30°C	-25°C	-23.3°C				-20°C	-15°C	-10°C				
						Watt	BTU	Input	COP							
220-240V/50Hz / 1 Ph.																
AZA2360Z	1/6	3.28	82	112	146	160	546	139	1.15	187	239	300	C.S.I.R	36-43/330	—	178
AZA2370Z	1/6	4.00	93	129	173	210	717	175	1.20	223	276	330	C.S.I.R	36-43/330	—	172
AZA2410Z	1/5	5.59	148	197	255	280	955	267	1.05	330	422	530	C.S.I.R	43-52/330	—	178
AE2410ZK	1/5	5.99	130	176	242	270	921	239	1.13	325	420	530	C.S.I.R	36-43/330	—	189
			150	198	258	284	969	213	1.33	336	430	540	C.S.R	36-43/330	5/450	189
AE2413ZK	1/4	6.92	168	223	297	325	1109	284	1.14	380	473	570	C.S.I.R	36-43/330	—	183
AE2416ZK	1/3	8.86	198	280	375	410	1399	352	1.16	485	601	720	C.S.I.R	36-43/330	—	186
			198	280	375	410	1399	303	1.35	485	601	720	C.S.R	36-43/330	8/440	189
AE2420ZK	1/2	12.04	328	385	454	480	1638	356	1.35	530	627	740	C.S.R	36-43/330	8/440	203
AE2425ZK	5/8	14.14	335	435	562	613	2092	488	1.26	725	930	1180	C.S.R	36-43/330	8/450	216
AE2428ZK	2/3	16.08	389	497	639	700	2388	560	1.25	820	1056	1320	C.S.R	43-52/330	8/450	216
CA2432Z	3/4	18.00	343	515	704	774	2641	624	1.24	920	1168	1440	C.S.R	88-106/330	15/440	215
CA2435Z	1	20.00	480	658	845	925	3156	740	1.25	1100	1375	1650	C.S.R	88-106/330	15/440	215
CA2440Z	1	22.30	485	680	927	1020	3480	864	1.18	1240	1624	2100	C.S.R	108-130/330	20/440	215
WJ2430ZK	2/3	19.80	151	348	600	703	2399	550	1.28	890	1232	1650	C.S.R	108-130/330	20/440	264
WJ2435ZK	7/8	21.50	251	479	748	850	2900	637	1.33	1067	1438	1850	C.S.R	108-130/330	20/440	264
WJ2440ZK	7/8	24.20	180	492	831	967	3299	731	1.32	1241	1693	2150	C.S.R	145-174/330	25/440	264
WJ2450ZK	1-1/4	26.75	413	685	996	1114	3801	865	1.29	1389	1839	2350	C.S.R	145-174/330	25/440	264
WJ2455ZK	1-3/8	30.50	677	949	1260	1378	4702	1050	1.31	1653	2103	2600	C.S.R	145-174/330	25/440	264
WJ2460Z	1-1/2	34.50	899	1171	1480	1600	5459	1143	1.40	1875	2395	2980	C.S.R	145-174/330	30/425	264
AW2450ZK	1-1/2	37.50	700	900	1140	1244	4245	929	1.34	1450	1780	2150	C.S.R	108-130/330	15/440	289
AW2462ZK	1-3/4	39.60	930	1165	1430	1525	5203	1116	1.37	1760	2178	2700	C.S.R	108-130/330	20/370	289
AW2464ZK	1-3/4	43.10	1004	1220	1475	1580	5391	1280	1.23	1800	2244	2750	C.S.R	130-156/330	30/440	289
AW2495ZK	2-3/8	53.50	1055	1568	2105	2322	7923	1613	1.44	2760	3520	4300	C.S.R	145-174/330	25/440	324
115V/60Hz / 1 Ph.																
AE2410Z-1	1/4	5.99	162	206	275	300	1024	285	1.05	355	444	540	C.S.I.R	108-130/250	—	188
AE2413Z-1	1/4	6.92	198	270	351	381	1300	375	1.02	450	560	674	C.S.I.R	108-130/250	—	188
AE2420Z-1	1/2	12.05	312	397	495	536	1829	505	1.06	630	823	1050	C.S.R	108-130/330	25/450	216
AE2425Z-1	5/8	10.90	376	488	620	674	2300	586	1.15	780	960	1150	C.S.R	108-130/330	20/440	200
CA2432Z-1	2/3	18.00	390	564	770	845	2883	754	1.12	1008	1285	1620	C.S.R	88-106/330	30/440	215
CA2435Z-1	5/6	20.00	437	658	900	995	3395	865	1.15	1200	1540	1900	C.S.R	130-156/330	30/440	215
CA2440Z-1	1	22.30	480	750	1041	1150	3924	1000	1.15	1360	1680	2030	C.S.R	243-292/250	35/440	215
WJ2435Z-1	3/4	21.50	215	453	735	850	2900	747	1.14	1104	1540	2000	C.S.R	189-227/250	20/425	264
WJ2450Z-1	1-1/4	26.75	532	790	1130	1269	4330	1035	1.23	1550	2020	2530	C.S.R	243-292/250	40/440	264
WJ2455Z-1	1-1/2	30.50	895	1154	1460	1583	5401	1275	1.24	1850	2300	2820	C.S.R	243-292/250	40/440	264
208-230V/60Hz / 1 Ph.																
AE2416ZK-2	1/3	8.86	222	313	420	463	1580	348	1.33	550	690	850	C.S.R	36-43/330	5/450	201
AE2420ZK-2	1/2	12.04	315	407	523	575	1962	475	1.21	678	868	1100	C.S.R	36-43/330	10/440	216
AE2425ZK-2	1/2	14.14	365	477	615	670	2286	546	1.23	798	1023	1300	C.S.R	36-43/330	12/440	216
AE2428ZK-2	2/3	16.08	400	555	730	800	2730	656	1.22	947	1200	1500	C.S.R	36-43/330	12/440	216
CA2432Z-2	3/4	18.00	410	580	785	860	2934	747	1.15	1025	1310	1640	C.S.R	43-52/330	20/440	215
CA2435Z-2	5/6	20.00	437	658	900	995	3395	917	1.09	1200	1540	1900	C.S.R	88-106/330	20/440	215
CA2440Z-2	1	22.30	470	716	1000	1115	3804	973	1.15	1340	1700	2100	C.S.R	43-52/330	15/440	215
WJ2440Z-2	1	24.20	490	735	1027	1145	3907	970	1.18	1400	1819	2300	C.S.R	108-130/330	20/425	264
WJ2450Z-2	1-1/4	26.75	550	830	1170	1290	4401	1080	1.19	1560	2050	2600	C.S.R	108-130/330	25/450	264
WJ2455Z-2	1-1/2	30.50	900	1160	1470	1590	5425	1275	1.25	1860	2320	2840	C.S.R	145-174/330	30/450	264

R404A LBP

Cooling Capacity (watt)

Model	Power (HP)	Disp. (cc)	ASHRAE 32 / Evaporating Temperature										Motor Type	Start Cap. (µF/VAC)	Run Cap. (µF/VAC)	Height "A" (mm)
			-35°C	-30°C	-25°C	-23.3°C				-20°C	-15°C	-10°C				
						Watt	BTU	Input	COP							

208-230V/60Hz / 1 Ph.

AW2450ZK-2	1-1/2	37.50	465	890	1393	1575	5374	1260	1.25	1976	2647	3410	C.S.R	161-193/330	20/440	289
AW2462ZK-2	1-3/4	39.60	550	1000	1515	1700	5800	1330	1.28	2100	2780	3550	C.S.R	161-193/330	20/450	289
AW2464ZK-2	1-3/4	43.10	1113	1458	1813	1938	6612	1475	1.31	2176	2542	2908	C.S.R	161-193/330	20/425	289
AW2495ZK-2	2-3/8	53.50	893	1523	2202	2450	8359	1800	1.36	2932	3716	4555	C.S.R	161-193/330	25/450	324
AW2510ZK-2	2-3/4	71.00	900	1680	2600	2946	10052	2806	1.05	3630	4750	6000	C.S.R	216-259/250	45/440	324
KA2512Z-2	3	93.00	1460	2280	3240	3625	12369	3120	1.16	4410	5720	7260	C.S.R	243-292/250	35/440	399

100V/50-60Hz / 1 Ph.

AE2410ZK-3	1/4	5.99	153	195	257	284	969	280	1.01	345	445	558	C.S.I.R	108-130/250	—	189
			158	222	301	333	1136	295	1.13	398	506	622				
AE2413ZK-3	1/3	6.92	168	223	297	325	1109	358	0.91	380	473	570	C.S.I.R	108-130/250	—	189
			202	273	353	385	1314	360	1.07	452	562	678				

380-420V/50Hz, 460V/60Hz / 3 Ph.

AW2450Z-9	1-1/4	37.50	700	960	1220	1320	4504	925	1.43	1520	1850	2200	3 Ph.	—	—	324
			800	1040	1330	1430	4879	1025	1.40	1625	1945	2280				
AW2464Z-9	1-3/4	43.10	704	1006	1450	1671	5701	1130	1.48	2199	3114	4200	3 Ph.	—	—	324
			759	1150	1680	1905	6500	1310	1.45	2360	3220	4300				
AW2495Z-9	2-3/8	53.50	1055	1568	2160	2393	8165	1560	1.53	2875	3661	4600	3 Ph.	—	—	324
			1200	1730	2320	2544	8680	1725	1.47	3000	3800	4700				
AW2510Z-9	2-1/2	59.00	1192	1772	2429	2697	9202	1693	1.59	3250	4174	5200	3 Ph.	—	—	324
			1230	1895	2620	2899	9891	1867	1.55	3430	4350	5400				
AW2512ZXG	3	71.00	1445	2130	2950	3282	11198	2550	1.29	4100	5492	7000	3 Ph.	—	—	324
			1545	2340	3330	3722	12699	2970	1.25	4508	5829	7300				

380V/60Hz / 3 Ph.

AW2450ZXI	1-1/2	37.50	720	970	1250	1348	4599	1000	1.35	1550	1890	2270	3 Ph.	—	—	324
AW2464ZXI	1-3/4	43.10	704	1006	1450	1680	5732	1250	1.34	2199	3114	4200	3 Ph.	—	—	324
AW2495ZXI	1-3/4	53.50	930	1550	2240	2480	8462	1740	1.43	2970	3740	4600	3 Ph.	—	—	324
AW2510ZXI	2	59.00	1205	1897	2640	2919	9960	2000	1.46	3562	4606	5700	3 Ph.	—	—	324

200-220V/50Hz, 200-230V/60Hz / 3 Ph.

AW2510ZXT	2-1/2	71.00	1097	1630	2230	2477	8452	2252	1.10	3000	3882	4850	3 Ph.	—	—	324
			1170	1842	2560	2843	9700	2585	1.10	3492	4514	5600				
KA2512ZXT	3	93.00	1300	1980	2900	3215	10970	2690	1.20	4000	5350	7100	3 Ph.	—	—	399
			1500	2300	3280	3643	12430	3050	1.19	4430	5750	7300				

R404A MBP/CBP

Cooling Capacity (Watt)

Model	Power (HP)	Disp. (cc)	ASHRAE 46 / Evaporating Temperature											Motor Type	Start Cap. (µF/VAC)	Run Cap. (µF/VAC)	Height "A" (mm)
			-20°C	-15°C	-10°C	-6.7°C				-5°C	0°C	5°C	+10°C				
						Watt	BTU	Input	COP								

380-420V/50Hz, 460V/60Hz / 3 Ph.

AW7512Z-9	1-1/2	37.50	1400	1900	2430	2872	9799	1525	1.88	3102	3900	4820	5863	3 Ph.	—	—	324
			1700	2260	2940	3447	11761	1810	1.90	3760	4630	5600	6600				
AW7514Z-9	1-7/8	43.10	1900	2380	3000	3502	11949	1850	1.89	3783	4800	5900	7150	3 Ph.	—	—	324
			2100	2850	3640	4250	14501	2228	1.91	4596	5730	7100	8795				
AW7516Z-9	2	53.50	1950	2670	3460	4038	13778	2353	1.72	4360	5400	6600	8000	3 Ph.	—	—	324
			2300	3110	4050	4736	16159	2778	1.70	5150	6450	7970	9620				
KA9522ZXG	2-3/4	65.00	2500	3550	4650	5598	19100	2625	2.13	6200	7900	9700	11596	3 Ph.	—	—	399
			3000	4150	5550	6536	22301	3035	2.15	7250	9200	11300	13475				

Cooling Capacity (Watt)																	
Model	Power (HP)	Disp. (cc)	ASHRAE 46 / Evaporating Temperature											Motor Type	Start Cap. (μF/VAC)	Run Cap. (μF/VAC)	Height "A" (mm)
			-20°C	-15°C	-10°C	-6.7°C				-5°C	0°C	5°C	+10°C				
						Watt	BTU	Input	COP								
380-420V/50Hz, 460V/60Hz /3 Ph.																	
KA9524ZYG	3	70.00	3100	4100	5200	6096	20800	2800	2.18	6660	8400	10400	12543	3 Ph.	—	—	399
			3500	4500	5800	6858	23399	3200	2.14	7500	9600	11900	14417				
KA9528ZYG	3-1/2	80.00	3600	4750	6000	7034	24000	3230	2.18	7610	9650	12000	15000	3 Ph.	—	—	399
			3900	5300	6870	8060	27501	3690	2.18	8840	11200	13800	16722				
KA9531ZYG	4	90.00	4100	5550	7130	8382	28599	3675	2.28	9200	11456	14000	16760	3 Ph.	—	—	399
			4500	5800	7720	9086	31001	4090	2.22	9940	12689	15900	19435				
KA9535ZYG	4-3/8	100.00	5000	6430	8060	9378	32000	4160	2.25	10180	12900	16000	19600	3 Ph.	—	—	399
			6000	7300	8900	10258	35000	4710	2.18	11000	13949	17200	21366				
KA9540ZYG	5	115.00	6200	7690	9450	10786	36800	4880	2.21	11630	14100	17000	20582	3 Ph.	—	—	399
			7200	8800	10400	11870	40500	5600	2.12	12700	15700	19400	23828				
200-220V/50Hz, 200-230V/60Hz / 3 Ph.																	
WJ9485ZXT	1-1/8	24.20	1100	1450	1830	2093	7141	1290	1.62	2250	2760	3350	4027	3 Ph.	—	—	264
			1300	1630	2100	2462	8400	1450	1.70	2670	3280	4000	4731				
WJ9490ZXT	1-1/8	26.70	1350	1700	2120	2461	8397	1410	1.75	2680	3300	4080	4900	3 Ph.	—	—	264
			1500	1930	2480	2880	9827	1610	1.79	3100	3800	4600	5426				
WJ9510ZXT	1-1/4	30.50	1450	1915	2400	2810	9588	1660	1.69	3010	3650	4400	5305	3 Ph.	—	—	264
			1700	2260	2850	3282	11198	1900	1.73	3529	4300	5200	6291				
AW7512ZXT	1-1/2	37.50	1300	1780	2260	2639	9004	1580	1.67	2860	3530	4330	5257	3 Ph.	—	—	324
			1600	2100	2693	3122	10652	1880	1.66	3370	4170	5100	6217				
AW7514ZXT	1-2/3	43.10	1650	2110	2692	3121	10649	1850	1.69	3390	4300	5300	6400	3 Ph.	—	—	324
			1800	2450	3163	3668	12515	2200	1.67	3980	4900	6000	7304				
AW7516ZXT	2	53.50	1900	2696	3500	4038	13778	2156	1.68	4360	5400	6650	8084	3 Ph.	—	—	324
			2300	3150	4105	4736	16159	2928	1.62	5120	6300	7800	9481				
AW7524ZXT	3	71.00	2700	3600	4500	5276	18002	2931	1.80	5700	7000	8700	10562	3 Ph.	—	—	324
			3100	4188	5436	6272	21400	3564	1.76	6850	8500	10400	12556				
KA9524ZXT	3	70.00	2700	3800	4950	5427	18517	2780	1.95	6300	7770	9350	11000	3 Ph.	—	—	399
			2900	4000	5200	5686	19401	2860	1.99	6600	8200	10100	12543				
KA9531ZXT	3-7/8	90.00	4000	5400	6900	7963	27170	3620	2.20	8600	10700	13200	15922	3 Ph.	—	—	399
			5000	6031	7352	8461	28870	3800	2.23	9360	12150	15000	18096				
KA9535ZXT	4-3/8	100.00	5900	7050	8415	9500	32414	4210	2.26	10250	12666	15500	18530	3 Ph.	—	—	399
			6200	7200	8800	10131	34567	4530	2.24	10995	14000	17200	21101				

R404A MBP/CBP

Cooling Capacity (Watt)																		
Model	Power (HP)	Disp. (cc)	ASHRAE 46 / Evaporating Temperature											Motor Type	Start Cap. (μF/VAC)	Run Cap. (μF/VAC)	Height "A" (mm)	
			-20°C	-15°C	-10°C	-6.7°C				-5°C	0°C	5°C	7.2°C					10°C
						Watt	BTU	Input	COP									
220-240V/50Hz / 1 Ph.																		
AE9420Z	1/5	6.92	260	354	455	527	1798	372	1.42	563	670	790	900	1005	C.S.R	36-43/330	8/450	196
AE9426Z	1/4	7.57	305	428	550	630	2150	450	1.40	674	804	940	1070	1175	C.S.I.R	36-43/330	—	204
BA7430Z	3/8	8.86	380	515	656	756	2579	495	1.53	808	960	1120	1212	1317	C.S.R	43-52/330	8/450	205
BA7440Z	1/2	12.04	495	650	830	967	3299	616	1.57	1030	1240	1480	1572	1677	C.S.R	36-43/330	15/450	215
BA9440Z	1/2	12.04	420	615	820	967	3299	616	1.57	1040	1260	1500	1750	1855	C.S.R	36-43/330	15/440	215
BA7443Z	1/2	14.14	630	815	1005	1143	3900	770	1.48	1220	1460	1720	1812	1917	C.S.R	36-43/330	20/440	215
BA7452Z	2/3	16.08	750	955	1170	1319	4500	895	1.47	1406	1630	1900	1992	2097	C.S.R	43-52/330	15/440	215
BA7459Z	3/4	18.00	780	1009	1265	1450	4947	1030	1.41	1530	1820	2100	2192	2297	C.S.R	43-52/330	20/450	215
CA7475Z	1	22.30	870	1216	1590	1846	6299	1374	1.34	1990	2410	2850	2942	3047	C.S.R	108-130/330	50/450	215
WJ9470Z	7/8	21.50	850	1180	1550	1810	6176	1050	1.72	1950	2400	2900	3290	3395	C.S.R	88-106/330	20/440	264
WJ9485Z	1-1/8	24.20	1200	1530	1900	2180	7438	1260	1.73	2350	2850	3450	3790	3895	C.S.R	88-106/330	25/450	264
WJ9490Z	1-1/8	26.70	1250	1600	2040	2345	8001	1400	1.68	2510	3050	3650	3986	4091	C.S.R	108-130/330	20/440	264
WJ9510Z	1-1/4	30.50	1400	1886	2375	2697	9202	1690	1.60	2900	3500	4200	4689	4794	C.S.R	108-130/330	25/450	264

R404A HBP

Cooling Capacity (Watt)

Model	Power (HP)	Disp. (cc)	ASHRAE 46 / Evaporating Temperature								Motor Type	Start Cap. (µF/VAC)	Run Cap. (µF/VAC)	Height "A" (mm)	
			-10°C	-5°C	0°C	5°C	7.2°C								+10°C
							Watt	BTU	Input	COP					
220-240V/50Hz / 1 Ph.															
AE4430Z	1/4	5.68	390	489	603	740	809	2760	400	2.02	907	C.S.I.R	36-43/330	—	183
AE4435Z	1/3	6.92	482	582	695	830	900	3071	492	1.83	1000	C.S.I.R	36-43/330	—	196
AE4440Z	1/3	7.57	550	670	806	960	1026	3501	590	1.74	1120	C.S.I.R	36-43/330	—	204
380-420V/50Hz, 460V/60Hz / 3 Ph.															
AW4524ZXG	2	43.10	2897	3780	4788	5920	6460	22042	2140	3.02	7185	3 Ph.	—	—	324
			3391	4453	5680	7000	7651	26105	2511	3.05	8511				
AW5524Z-9	2	39.60	2616	3405	4323	5350	5833	19902	1927	3.03	6487	3 Ph.	—	—	324
			3103	4076	5199	6390	7002	23891	2304	3.04	7791				
AW5526Z-9	2-1/6	43.10	2897	3771	4788	5925	6460	22042	2140	3.02	7185	3 Ph.	—	—	324
			3391	4453	5680	7000	7650	26102	2510	3.05	8511				
AW5534Z-9	3	53.50	3787	4827	5940	7180	7870	26852	2750	2.86	8900	3 Ph.	—	—	324
			4425	5640	6972	8550	9350	31902	3250	2.88	10500				
AW5538Z-9	3-1/6	59.00	4412	5623	6850	8350	9168	31281	3235	2.83	10392	3 Ph.	—	—	324
			5194	6607	8184	10000	10976	37450	3840	2.86	12306				
AW5540Z-9	3-1/3	63.00	4677	5900	7350	8900	9720	33165	3470	2.80	11000	3 Ph.	—	—	324
			5459	6943	8601	10550	11535	39357	4225	2.73	12932				
AW5545Z-9	3-2/3	71.00	5420	6909	8479	10200	11265	38436	4085	2.76	12768	3 Ph.	—	—	324
			6283	7991	9899	12100	13275	45294	4890	2.71	14884				
KA5542ZXG	3-1/2	65.00	5183	6550	8050	9600	10405	35502	3250	3.20	11596	3 Ph.	—	—	399
			5954	7576	9345	11200	12163	41500	3810	3.19	13475				
KA5544ZXG	3-2/3	70.00	5823	7157	8650	10360	11255	38402	3460	3.25	12543	3 Ph.	—	—	399
			6370	8105	9998	12050	13013	44400	4050	3.21	14417				
KA5552ZXG	4-1/3	80.00	6672	8261	9966	11950	12896	44001	4030	3.20	14372	3 Ph.	—	—	399
			7388	9401	11597	13900	15094	51501	4755	3.17	16722				
KA5558ZXG	4-5/6	90.00	6593	8790	11200	13800	15035	51299	4555	3.30	16760	3 Ph.	—	—	399
			7730	9990	12500	15500	17116	58400	5300	3.23	19435				
KA5564ZXG	5-1/3	100.00	8230	10192	12506	15150	16413	56001	5170	3.17	18296	3 Ph.	—	—	399
			8498	10983	13949	17100	18816	64200	6100	3.08	21366				
KA5572ZXG	6	115.00	9258	11465	14100	17000	18464	62999	6040	3.06	20582	3 Ph.	—	—	399
			9477	12249	15500	19300	20985	71601	7120	2.95	23828				
LA5590ZXG	7-1/2	174.00	7620	10900	14700	19300	21634	73815	7230	2.99	25000	3 Ph.	—	—	438
			9122	12847	17600	23100	25961	88579	8850	2.93	30200				
LA5610ZXG	8-1/3	197.00	11085	14700	18600	23200	25498	86999	8790	2.90	28739	3 Ph.	—	—	454
			13372	17700	22639	28200	30774	105001	10600	2.90	34500				
LA5612ZXG	10	211.00	12375	16188	20600	25700	28429	97000	9800	2.90	31965	3 Ph.	—	—	454
			14868	19700	25000	31600	35170	120000	12120	2.90	39900				
200-220V/50Hz, 200-230V/60Hz / 3 Ph.															
KA5542ZXT	5-1/4	70.00	5548	6950	8480	10200	11137	37999	3420	3.26	12412	3 Ph.	—	—	399
			6083	7750	9520	11500	12427	42401	3760	3.31	13767				
KA5555ZXT	7	90.00	6290	8300	10600	13200	14344	48942	4560	3.15	15991	3 Ph.	—	—	399
			7243	9361	11800	14600	16038	54722	5150	3.11	18211				
KA5562ZXT	8	100.00	8339	10346	12717	15300	16690	56950	5230	3.19	18605	3 Ph.	—	—	399
			8469	10778	13500	16750	18464	62999	5885	3.14	20966				

R407C MBP/CBP

Cooling Capacity (Watt)																	
Model	Power (HP)	Disp. (cc)	ASHRAE 46 / Evaporating Temperature											Motor Type	Start Cap. (μ F/VAC)	Run Cap. (μ F/VAC)	Height "A" (mm)
			-20°C	-15°C	-10°C	-6.7 °C				-5°C	0°C	5°C	10°C				
						Watt	BTU	Input	COP								
220-240V/50Hz / 1 Ph.																	
AE7445GK	5/8	16.08	670	820	990	1113	3798	800	1.39	1190	1440	1700	2000	C.S.R	36-43/330	15/440	216
CA7457G	3/4	18.00	700	930	1170	1337	4562	899	1.49	1440	1700	2000	2300	C.S.R	36-43/330	15/440	216
WJ9460GK	3/4	19.80	850	1070	1315	1490	5084	855	1.74	1585	1900	2250	2650	C.S.R	88-106/330	15/425	264
WJ9470GK	1	21.55	890	1127	1450	1700	5800	958	1.77	1850	1300	2800	3400	C.S.R	88-106/330	20/425	264
WJ9480GK	1-1/8	24.20	950	1250	1600	1900	6483	1100	1.73	2050	2550	3070	3600	C.S.R	88-106/330	25/440	264
WJ9485GK	1-1/4	26.70	970	1330	1780	2140	7302	1246	1.72	2345	2900	3500	4070	C.S.R	145-175/330	25/440	264
WJ9510GK	1-1/2	30.50	1200	1630	2100	2460	8394	1425	1.73	2640	3210	3800	4400	C.S.R	145-174/330	25/450	264
208-230V/60Hz / 1 Ph.																	
AE7445GK-2	7/8	14.14	950	1340	1770	2080	7097	970	2.14	2260	2810	3400	4000	C.S.R	36-43/330	15/440	214
WJ9460G-2	3/4	19.80	930	1240	1580	1846	6299	1050	1.76	1985	2450	2950	3480	C.S.R	88-106/330	20/440	264
220-240V/50Hz, 208-230V/60Hz / 1 Ph.																	
WJ9480G-6	1-1/8	24.20	960	1300	1660	1917	6541	1100	1.74	2050	2490	2950	3420	C.S.R	88-106/330	25/450	264
			1200	1590	2030	2345	8001	1360	1.72	2550	3120	3750	4400				

R407C HBP

Cooling Capacity (Watt)																	
Model	Power (HP)	Cooling Type	Disp. (cc)	ASHRAE 46 / Evaporating Temperature										Motor Type	Start Cap. (μ F/VAC)	Run Cap. (μ F/VAC)	Height "A" (mm)
				-10°C	-5°C	0°C	5°C	+7.2°C				10°C					
								Watt	BTU	Input	COP						
220-240V/50Hz / 1 Ph.																	
AW4515GK	1-1/2	F	30.50	2000	2519	3100	3790	4085	13938	1390	2.94	4520	C.S.R	108-130/330	25/440	289	
AW4517GK	1-1/2	F	32.70	2200	2760	3370	4080	4440	15149	1536	2.89	4900	C.S.R	108-130/330	30/440	289	
AW4519GK	1-3/4	F	35.60	2450	3040	3720	4470	4835	16497	1688	2.86	5290	C.S.R	108-130/330	25/440	289	
AW4520GK	1-3/4	F	37.50	2750	3380	4080	4850	5200	17742	1738	2.99	5700	C.S.R	108-130/330	35/440	324	
AW4522GK	2	F	39.60	3040	3730	4470	5280	5667	19336	1895	2.99	6170	C.S.R	108-130/330	35/440	324	
AW4524GK	2	F	43.10	3400	4120	4890	5740	6140	20950	2090	2.94	6680	C.S.R	108-130/330	45/440	324	
AW4528GK	2-1/2	F	48.40	4100	4900	5750	6690	7108	24252	2415	2.94	7700	C.S.R	130-156/330	35/440	324	
AW4532GK	2-3/4	F	53.50	4600	5470	6400	7400	7870	26852	2678	2.94	8500	C.S.R	130-156/330	50/440	324	
208-230V/60Hz / 1 Ph.																	
AW4519GK-2	1-2/3	F	35.60	2540	3150	3835	4610	4974	16971	1950	2.55	5455	C.S.R	88-106/330	30/440	289	
AW4524GK-2	2	F	43.10	4100	4900	5750	6690	7100	24225	2420	2.93	7700	C.S.R	108-130/330	35/440	324	
AW4528GK-2	2-1/2	F	48.40	4800	5650	6640	7660	8148	27801	2780	2.93	8800	C.S.R	130-156/330	35/440	324	
AW4532GK-2	2-2/3	F	53.50	5680	6600	7640	8800	9370	31970	3228	2.90	10100	C.S.R	130-156/330	50/440	324	

R22 MBP/CBP

Cooling Capacity (Watt)																	
Model	Power (HP)	Disp. (cc)	ASHRAE 46 / Evaporating Temperature											Motor Type	Start Cap. (μ F/VAC)	Run Cap. (μ F/VAC)	Height "A" (mm)
			-20°C	-15°C	-10°C	-6.7°C				-5°C	0°C	5°C	+10°C				
						Watt	BTU	Input	COP								
220-240V/50Hz / 1 Ph.																	
AE6412EK	1/6	4.50	130	190	248	290	989	240	1.21	313	380	450	525	R.S.I.R.	—	—	189
AE7415EK	1/5	5.48	150	225	307	370	1262	310	1.19	405	505	607	715	C.S.I.R	36-43/250	—	189
AE7422EK	1/4	7.57	250	360	468	550	1877	420	1.31	595	720	850	997	C.S.I.R	36-43/330	—	189
AE9422EK	1/4	7.57	280	390	506	595	2030	417	1.43	640	783	937	1090	C.S.I.R	36-43/330	—	203
AE7426EK	1/4	8.86	300	410	540	640	2184	480	1.33	705	885	1080	1286	C.S.I.R	36-43/330	—	201
AE7435EK	7/16	12.04	450	600	760	870	2968	550	1.58	935	1120	1330	1576	C.S.R	36-43/330	8/440	216
AE7440EK	1/2	14.14	630	768	910	1010	3446	660	1.53	1073	1243	1440	1680	C.S.R	36-43/330	12/440	216
BA7440EK	1/2	14.14	630	768	910	1010	3446	660	1.53	1073	1243	1440	1680	C.S.R	36-43/330	12/440	216

R22 MBP/CBP

Cooling Capacity (Watt)																	
Model	Power (HP)	Disp. (cc)	ASHRAE 46 / Evaporating Temperature											Motor Type	Start Cap. (μ F/VAC)	Run Cap. (μ F/VAC)	Height "A" (mm)
			-20°C	-15°C	-10°C	-6.7°C				-5°C	0°C	5°C	+10°C				
						Watt	BTU	Input	COP								
220-240V/50Hz / 1 Ph.																	
BA7445EK	5/8	16.08	650	800	980	1113	3798	800	1.39	1190	1450	1730	2016	C.S.R	36-43/330	15/440	216
WJ9460EK	2/3	19.80	600	896	1231	1490	5084	855	1.74	1640	2130	2670	3288	C.S.R	88-106/330	15/440	264
WJ9470EK	3/4	21.55	800	1121	1459	1700	5800	958	1.77	1855	2290	2800	3326	C.S.R	88-106/330	20/440	264
WJ9480EK	4/5	24.20	1000	1324	1651	1900	6483	1100	1.73	2050	2520	3100	3737	C.S.R	88-106/330	25/450	264
WJ9485EK	1	26.70	1080	1447	1860	2140	7302	1246	1.72	2311	2850	3500	4208	C.S.R	145-174/330	25/425	264
WJ9510EK	1	30.50	1300	1691	2141	2460	8394	1425	1.73	2640	3180	3800	4514	C.S.R	145-174/330	25/440	264
WJ9513E	1-1/3	34.50	1700	2139	2665	3031	10342	1638	1.85	3251	3928	4730	5665	C.S.R	108-130/330	30/440	264
208-230V/60Hz / 1 Ph.																	
AE7415EK-2	1/6	5.48	233	303	380	430	1467	360	1.19	465	565	680	804	C.S.I.R	36-43/250	—	189
AE7422EK-2	1/4	7.57	400	490	590	656	2238	490	1.34	695	810	930	1060	C.S.I.R	36-43/250	—	189
AE7426EK-2	1/3	8.86	500	600	705	785	2678	577	1.36	820	940	1070	1210	C.S.I.R	36-43/250	—	201
AE7435EK-2	2/5	12.04	650	770	895	985	3361	690	1.43	1030	1170	1310	1460	C.S.R	36-43/330	8/450	216
AE7440EK-2	1/2	14.14	800	930	1065	1173	4002	793	1.48	1240	1420	1600	1780	C.S.R	36-43/330	15/440	216
AE7445E-2	1/2	16.08	900	1030	1185	1300	4436	987	1.32	1365	1557	1770	2000	C.S.R	36-43/330	25/440	216
WJ9460E-2	3/4	19.80	1200	1445	1675	1846	6299	1050	1.76	1935	2200	2480	2750	C.S.R	88-106/330	20/440	264

R22 HBP

Cooling Capacity (Watt)																
Model	Power (HP)	Disp. (cc)	ASHRAE 46 / Evaporating Temperature										Motor Type	Start Cap. (μ F/VAC)	Run Cap. (μ F/VAC)	Height "A" (mm)
			-10°C	-5°C	0°C	5°C	+7.2°C				+10°C					
							Watt	BTU	Input	COP						
220-240V/50Hz / 1 Ph.																
AE4430EK	1/4	6.92	472	568	674	795	852	2907	467	1.82	928	C.S.R	36-43/330	8/450	202	
AE4440EK	1/3	7.57	520	641	777	925	1000	3412	453	2.21	1090	C.S.R	36-43/330	8/450	202	
AE4448EK	3/8	8.85	630	774	929	1095	1172	3999	560	2.09	1280	C.S.R	36-43/330	8/450	202	
AE4474EK	5/8	14.14	883	1100	1360	1650	1800	6142	840	2.14	1980	C.S.R	36-43/330	15/440	212	
AW4515EK	3/8	30.50	1546	2117	2809	3650	4085	13938	1390	2.94	4677	C.S.R	108-130/330	25/440	289	
AW4517EK	1-1/2	32.70	1696	2303	3055	3985	4440	15149	1536	2.89	5159	C.S.R	108-130/330	30/440	289	
AW4519EK	5/8	35.60	1960	2620	3415	4360	4835	16497	1688	2.86	5600	C.S.R	108-130/330	25/440	289	
AW4520EK	3/4	37.50	2287	2989	3800	4750	5200	17742	1738	2.99	5829	C.S.R	108-130/330	35/440	324	
AW4522EK	2	39.60	2397	3228	4145	5180	5667	19336	1895	2.99	6336	C.S.R	108-130/330	35/440	324	
AW4524EK	2	43.10	3350	4100	4908	5750	6140	20950	2090	2.94	6700	C.S.R	108-130/330	45/440	324	
AW4528EK	3/8	48.40	2900	3889	5055	6430	7108	24252	2415	2.94	7986	C.S.R	130-156/330	35/440	324	
AW4530EK	1/2	50.60	3706	4604	5608	6760	7327	25000	2498	2.93	8101	C.S.R	88-106/330	50/440	324	
AW4532EK	2-3/4	53.50	3576	4691	5863	7200	7870	26852	2678	2.94	8870	C.S.R	130-156/330	50/440	324	
208-230V/60Hz / 1 Ph.																
AE4474EK-2	3/4	14.14	1087	1380	1675	2000	2165	7387	1070	2.02	2364	C.S.R	36-43/330	15/440	216	
AW4528EK-2	3/4	48.40	2962	4200	5600	7300	8148	27801	2780	2.93	9225	C.S.R	130-156/330	35/440	324	
AW4532EK-2	3	53.50	3200	4400	6000	8150	9370	31970	3228	2.90	11040	C.S.R	130-156/330	50/440	324	

R410A AC

Cooling Capacity (Watt)																
Model	Power (HP)	Disp. (cc)	ASHRAE 46 / Evaporating Temperature								Motor Type	Start Cap. (μ F/VAC)	Run Cap. (μ F/VAC)	Height "A" (mm)		
			-10°C	-5°C	0°C	5°C	+7.2°C								+10°C	+15°C
							Watt	BTU	Input	EER						
220-240V/50Hz / 1 Ph.																

Cooling Capacity (Watt)																
Model	Power (HP)	Disp. (cc)	ASHRAE 46/ Evaporating Temperature										Motor Type	Start Cap. (μ F/VAC)	Run Cap. (μ F/VAC)	Height "A" (mm)
			-10°C	-5°C	0°C	5°C	+7.2°C				+10°C	+15°C				
							Watt	BTU	Input	EER						
220-240V/50Hz / 1 Ph.																
AW5517B	1-1/2	25.84	2066	2269	3367	4168	4634	15810	1550	10.20	5370	6916	P.S.C	-	40/440	324
AW5520B	1-3/4	27.80	2270	2900	3700	4580	4983	17550	1725	10.10	5900	7600	P.S.C	-	40/440	324
AW5522B	2	30.50	2440	3260	4120	5050	5686	19401	1880	10.32	6360	8570	P.S.C	-	45/440	324
AW5524B	2	32.70	2530	3350	4300	5405	6010	20506	2010	10.20	6900	9230	P.S.C	-	60/440	337
AW5528B	2-1/2	35.60	3130	4120	5240	6500	6950	23713	2325	10.20	8300	10670	P.S.C	-	60/440	337
AW5530B	2-1/2	37.50	3260	4280	5480	6800	7371	25150	2490	10.10	8500	11100	P.S.C	-	50/440	324
AW5532B	2-3/4	39.60	4100	4990	6030	7250	7913	26999	2673	10.10	9100	12000	P.S.C	-	60/440	337
AW5535B	3	43.10	3704	4980	6345	7850	8593	29319	2875	10.20	10000	13200	P.S.C	-	60/440	337
AW5540B	3	48.40	4980	6100	7500	9070	9906	33799	3530	9.57	11300	14120	P.S.C	-	60/440	324
AW5542B	3-1/2	50.60	5117	6350	7800	9450	10317	35202	3700	9.51	12200	16750	P.S.C	-	60/440	324
208-230V/60Hz / 1 Ph.																
AW5517B-2	1-1/2	25.84	2190	2792	2901	3592	4928	16814	1655	10.16	5370	6916	P.S.C	-	40/440	324
AW5520B-2	1-3/4	27.80	2542	3240	4100	5140	6008	20499	2040	10.05	6600	8588	P.S.C	-	35/440	337
AW5524B-2	2	32.70	3087	4020	5130	6570	7414	25297	2480	10.20	8700	11445	P.S.C	-	50/440	337
AW5530B-2	2-1/2	37.50	3782	4965	6300	7890	8702	29691	2910	10.20	10100	13098	P.S.C	-	45/440	337
AW5532B-2	2-3/4	39.60	4920	5964	7236	8600	9487	32370	3375	9.59	11000	14520	P.S.C	-	50/440	324
AW5535B-2	3	43.10	4482	5929	7677	9550	10466	35710	3723	9.59	12050	16104	P.S.C	-	60/440	324
AW5540B-2	3-1/2	48.40	6199	7600	9135	10900	12007	40968	4246	9.65	14000	18215	P.S.C	-	60/440	324

R407C AC

Cooling Capacity (Watt)																
Model	Power (HP)	Disp. (cc)	ASHRAE 46/ Evaporating Temperature										Motor Type	Start Cap. (μ F/VAC)	Run Cap. (μ F/VAC)	Height "A" (mm)
			-10°C	-5°C	0°C	5°C	+7.2°C				10°C	+15°C				
							Watt	BTU	Input	EER						
220-240V/50Hz / 1 Ph.																
AW5513GK	1-1/2	30.50	1376	1810	2390	3040	3380	11533	1317	8.76	3860	4861	P.S.C	—	25/440	289
AW5515GK	1-1/2	32.70	1590	2072	2650	3370	3800	12966	1483	8.74	4400	5655	P.S.C	—	30/440	289
AW5517GK	1-3/4	35.60	2020	2545	3120	3850	4170	14228	1626	8.75	4800	6163	P.S.C	—	30/440	289
AW5518GK	1-3/4	37.50	1965	2600	3250	4100	4526	15443	1646	9.38	5200	6680	P.S.C	—	35/440	289
AW5519GK	2	39.60	2143	2843	3632	4500	4952	16896	1808	9.35	5750	7460	P.S.C	—	35/440	289
AW5520GK	2	43.10	2193	2889	3750	4800	5260	17947	1983	9.05	6100	7910	P.S.C	—	45/440	324
AW5525GK	2-1/2	48.40	2765	3610	4600	5880	6527	22270	2265	9.83	7500	9350	P.S.C	—	35/440	324
AW5527GK	2-1/2	50.60	2929	3780	4820	6000	6598	22512	2403	9.37	7580	9972	P.S.C	—	50/440	324
AW5530GK	2-	53.50	3576	4400	5300	6400	7033	23997	2430	9.88	8100	10173	P.S.C	—	50/440	324
380-420V/50Hz, 460V/60Hz / 3 Ph.																
AW5519G-9	1-1/2	39.60	1913	2543	3285	4160	4602	15702	1536	10.22	5200	6359	3 Ph.	—	—	324
			2311	3054	3925	4985	5539	18899	1854	10.19	6400	8026				
AW5524G-9	2	43.10	2639	3408	4260	5280	5800	19790	1918	10.32	6500	7863	3 Ph.	—	—	324
			3120	4051	5100	6300	6908	23570	2278	10.35	7730	9326				
AW5528G-9	2-1/3	48.40	3049	3994	5053	6210	6800	23202	2230	10.40	7600	9042	3 Ph.	—	—	324
			3679	4834	6133	7580	8270	28217	2670	10.57	9260	10945				
AW5532G-9	2-5/8	53.50	3564	4504	5582	6770	7440	25385	2520	10.07	8300	9911	3 Ph.	—	—	324
			4295	5469	6789	8300	9086	31001	3030	10.23	10250	12375				

Cooling Capacity (Watt)

Model	Power (HP)	Disp. (cc)	ASHRAE 46 / Evaporating Temperature										Motor Type	Start Cap. (µF/VAC)	Run Cap. (µF/VAC)	Height "A" (mm)
			-10°C	-5°C	0°C	5°C	+7.2°C				10°C	+15°C				
							Watt	BTU	Input	EER						
380-420V/50Hz, 460V/60Hz / 3 Ph.																
KA5560GXG	5	100.00	6600	8584	11044	14010	15534	53002	4736	11.19	17800	22026	3 Ph.	—	—	399
			6706	9123	11881	15250	16999	58001	5466	10.61	19400	23831				
LA5590GXG	7-1/2	174.00	10269	13240	16524	20250	21980	74996	7580	9.89	24600	29085	3 Ph.	—	—	438
			10556	14600	19040	24100	26378	90002	9090	9.90	29700	35952				
LA5612GXG	10	211.00	14259	17630	21523	26000	28430	97003	9800	9.90	32000	38309	3 Ph.	—	—	438
			17624	22090	27015	32500	35170	120000	12120	9.90	38800	45793				

R22 AC

Cooling Capacity (Watt)

Model	Power (HP)	Disp. (cc)	ASHRAE 46 / Evaporating Temperature										Motor Type	Start Cap. (µF/VAC)	Run Cap. (µF/VAC)	Height "A" (mm)
			-10°C	-5°C	0°C	5°C	+7.2°C				+10°C	+15°C				
							Watt	BTU	Input	EER						
220-240V/50Hz / 1 Ph.																
WJ5510EK	3/4	19.80	1285	1653	2060	2500	2690	9178	1094	8.39	2957	3460	P.S.C.	—	15/440	264
WJ5513EK	1-1/15	21.50	1363	1820	2343	2930	3165	10799	1218	8.87	3536	4200	P.S.C.	—	20/440	264
WJ5515EK	1-1/15	24.20	1590	2075	2620	3220	3517	12000	1360	8.82	3925	4700	P.S.C.	—	25/440	264
WJ5516EK	1-1/3	26.75	1895	2390	2960	3600	3927	13399	1550	8.64	4350	5200	P.S.C.	—	25/440	264
WJ5518EK	1-1/2	30.50	2014	2617	3291	4055	4425	15098	1780	8.48	4911	5820	P.S.C.	—	25/440	264
AW5519EK	1-1/2	35.60	1960	2620	3415	4340	4835	16497	1688	9.77	5500	6900	P.S.C.	—	30/440	289
AW5520EK	1-3/4	37.50	2258	3000	3850	4760	5200	17742	1738	10.21	5820	6930	P.S.C.	—	35/440	324
AW5522EK	2	39.60	2455	3230	4100	5000	5667	19336	1895	10.20	6000	7050	P.S.C.	—	35/440	324
AW5524EK	2	43.10	2641	3500	4440	5560	6140	20950	2089	10.03	6850	8200	P.S.C.	—	45/440	324
AW5528EK	2-3/8	48.40	3118	4100	5239	6500	7108	24252	2415	10.04	8250	10500	P.S.C.	—	35/440	324
AW5530EK	2-1/2	50.60	3615	4520	5650	6830	7327	25000	2498	10.01	8350	10000	P.S.C.	—	50/440	324
AW5532EK	2-3/4	53.50	3437	4530	5796	7220	7870	26852	2678	10.03	9000	11000	P.S.C.	—	50/440	324
AW5535EK	3	59.00	3786	5000	6350	8000	8675	29599	3100	9.55	10005	12300	P.S.C.	—	60/440	324
AW5538E	3-1/6	63.00	4500	5660	7000	8500	9232	31500	3100	10.16	10200	12100	P.S.C.	—	60/440	324
AW5542E	3-1/2	70.95	5943	7067	8300	9750	10258	35000	3550	9.86	11700	14000	P.S.C.	—	60/440	324
208-230V/60Hz / 1 Ph.																
WJ5513EK-2	1-1/15	21.50	1649	2205	2835	3500	3810	13000	1485	8.75	4250	5100	P.S.C.	—	25/440	264
WJ5515EK-2	1-1/15	24.20	1927	2500	3158	3870	4220	14399	1717	8.39	4749	5700	P.S.C.	—	25/440	264
WJ5516EK-2	1-1/3	26.75	2175	2814	3467	4300	4720	16105	1925	8.37	5324	6450	P.S.C.	—	25/440	264
WJ5518EK-2	1-1/2	30.50	2625	3246	4072	5000	5480	18698	2230	8.38	6144	7500	P.S.C.	—	30/440	264
AW5519EK-2	1-5/8	35.60	2457	3271	4173	5250	5757	19643	2040	9.63	6500	7800	P.S.C.	—	35/440	289
AW5520EK-2	1-2/3	37.50	2601	3466	4440	5600	5980	20404	2030	10.05	6950	8400	P.S.C.	—	35/440	324
AW5522EK-2	1-5/6	39.60	2705	3605	4680	6000	6520	22246	2250	9.89	7500	9200	P.S.C.	—	30/440	324
AW5524EK-2	2	43.10	3021	4030	5200	5660	7100	24225	2480	9.77	8200	10300	P.S.C.	—	40/440	324
AW5528EK-2	2-1/3	48.40	3954	4900	6100	7500	8170	27876	2830	9.85	9173	11000	P.S.C.	—	40/440	324
AW5530EK-2	2-1/2	50.60	4338	5324	6600	8100	8900	30367	3035	10.01	10300	12900	P.S.C.	—	50/440	324
AW5532EK-2	2-2/3	53.50	4598	5750	7050	8700	9370	31970	3228	9.90	11000	14000	P.S.C.	—	50/440	324
AW5535EK-2	3	59.00	5075	6250	7750	9550	10200	34802	3640	9.56	12300	16000	P.S.C.	—	60/440	324
AW5538E-2	3	63.00	5296	6608	8161	10000	10958	37389	3790	9.87	12600	15800	P.S.C.	—	60/440	324
380-420V/50Hz, 460V/60Hz / 3 Ph.																
AW5522E-9	1-3/4	39.60	2307	3003	3812	4730	5143	17548	1700	10.32	5711	6800	3 Ph.	—	—	324
			2754	3616	4600	5700	6213	21199	2020	10.49	6930	8300				
AW5524E-9	2	43.10	2602	3387	4300	5290	5802	19796	1918	10.32	6453	7800	3 Ph.	—	—	324
			3067	4028	5138	6350	6920	23611	2278	10.36	7730	9200				

Cooling Capacity (Watt)

Model	Power (HP)	Disp. (cc)	ASHRAE 46 / Evaporating Temperature										Motor Type	Start Cap. (µF/VAC)	Run Cap. (µF/VAC)	Height "A" (mm)	
			-10°C	-5°C	0°C	5°C	+7.2°C				+10°C	+15°C					
							Watt	BTU	Input	EER							
380-420V/50Hz, 460V/60Hz / 3 Ph.																	
AW5528E-9	2-1/2	48.40	3050	3970	5040	6220	6800	23202	2230	10.40	7550	9000	3 Ph.	—	—	324	
			3665	4813	6140	7580	8270	28217	2670	10.57	9300	11200					
AW5530E-9	2-1/2	50.60	3527	4460	5517	6700	7327	25000	2400	10.42	8260	10100	3 Ph.	—	—	324	
			4224	5372	6655	8100	8909	30398	2900	10.48	9998	12000					
AW5532E-9	2-3/4	53.50	3580	4563	5600	6800	7440	25385	2520	10.07	8433	10500	3 Ph.	—	—	324	
			4300	5469	6775	8300	9086	31001	3030	10.23	10187	12300					
AW5535E-9	2-3/4	59.00	4017	5120	6283	7650	8353	28500	3234	8.81	9470	11600	3 Ph.	—	—	324	
			4816	6100	7600	9300	10200	34802	3925	8.87	11400	13700					
AW5538E-9	2-3/4	63.00	4296	5476	6720	8200	8970	30606	3100	9.87	10204	12600	3 Ph.	—	—	324	
			5117	6508	8062	9900	10845	37003	3770	9.82	12224	15000					
AW5542E-9	2-3/4	71.00	4976	6250	7784	9500	10390	35451	3625	9.78	11806	14500	3 Ph.	—	—	324	
			5891	7493	9282	11450	12515	42701	4440	9.62	14160	17300					
KA5538EXG	3	65.00	4538	5600	6700	8100	8793	30002	2730	10.99	9930	12300	3 Ph.	—	—	399	
			5272	6650	8200	9990	10844	37000	3286	11.26	12091	14400					
KA5542EXG	3-1/2	70.00	4935	6112	7499	9080	9965	34001	3047	11.16	11272	13900	3 Ph.	—	—	399	
			5606	7200	9000	11050	12017	41002	3630	11.30	13400	16000					
KA5550EXG	4	80.00	5606	7200	9000	11050	12017	41002	3686	11.12	13400	16000	3 Ph.	—	—	399	
			7029	8900	11000	13240	14360	48996	4365	11.22	15909	18800					
KA5555EXG	4-1/2	90.00	6760	8372	10300	12400	13482	46001	4110	11.19	15029	18000	3 Ph.	—	—	399	
			7280	9409	11900	14700	16120	55001	4975	11.06	18304	22000					
KA5560EXG	5	100.00	7232	9346	11700	14370	15534	53002	4736	11.19	17410	21000	3 Ph.	—	—	399	
			8294	10554	13000	15680	17000	58004	5466	10.61	18932	22500					
KA5570EXG	6	115.00	8294	10554	13000	15680	17000	58004	5466	10.61	18932	22500	3 Ph.	—	—	399	
			9981	12700	15667	18900	20516	70001	6618	10.58	22909	28000					
LA5590EXG	7-1/2	174.00	7742	11200	15200	19800	21980	74996	7580	9.89	25000	30500	3 Ph.	—	—	438	
			9267	13700	18600	24000	26378	90002	9090	9.90	30000	36700					
LA5610EXG	9	197.00	11085	14800	18856	23300	25498	86999	8790	9.90	28500	34400	3 Ph.	—	—	454	
			13372	17478	22639	28200	30774	105001	10600	9.91	34311	41000					
LA5612EXG	10	211.00	12375	16188	20968	25970	28430	97003	9800	9.90	31965	38500	3 Ph.	—	—	454	
			14868	19443	25220	32000	35170	120000	12120	9.90	39400	47500					
380V/60Hz / 3 Ph.																	
KA5560EXI	5	100.00	8294	10600	13300	16100	17430	59471	5550	10.72	19200	22400	3 Ph.	—	—	399	
LA5590EXI	7-1/2	174.00	9267	13700	18600	24000	26378	90002	9090	9.90	29800	36000	3 Ph.	—	—	438	
LA5610EXI	9	197.00	13372	17478	22639	28200	30774	105001	10600	9.91	34311	40900	3 Ph.	—	—	454	
LA5612EXI	10	211.00	14868	19443	25220	31800	35170	120000	12120	9.90	40000	50000	3 Ph.	—	—	454	
200-220V/50Hz, 200-230V/60Hz / 3 Ph.																	
KA5550EXT	4	80.00	5906	7313	8822	10600	11560	39446	3536	11.16	12990	15500	3 Ph.	—	—	399	
			6607	8407	10300	12430	13629	46502	4150	11.21	15260	18500					
KA5555EXT	4-1/2	90.00	6794	8414	10324	12450	13600	46403	4160	11.15	15179	18000	3 Ph.	—	—	399	
			7207	9221	11711	14500	15914	54300	4860	11.17	18121	22500					
LA5590EXT	7-1/2	174.00	7742	11200	15200	19800	21980	74999	7580	9.89	25000	30500	3 Ph.	—	—	454	
			9267	13600	18500	24000	26400	90002	9090	9.90	30000	36500					
LA5610EXT	9	197.00	11085	14800	18856	23300	25498	86999	8790	9.90	28500	34600	3 Ph.	—	—	454	
			13372	17478	22639	28200	30774	105001	10600	9.91	34311	41000					
LA5612EXT	10	211.00	12375	16188	20800	25900	28430	97003	9800	9.90	31965	39000	3 Ph.	—	—	454	
			14868	19700	25400	32000	35170	120000	12120	9.90	39500	48000					

CONDENSING UNIT

Model	App.	HP	Motor Type	Receiver Type	Nominal Capacity				Fan Motor		Fan Blade		Dimensions (mm.)		
					Watt		BTU/Hr		Output	FLA.	Blade	Diameter			
					50 Hz	60 Hz	50 Hz	60 Hz	Watt	Amps			inch (OD)	H	D
R134a															
CAE 1360YB-1	HBP	1/16	R.S.I.R.	WITH	-	189	-	645	9	0.25	5	9.05	279	470	330
CAE 2410YA	LBP	2/9	C.S.I.R.	LESS	270	-	921	-	13	0.32	5	9.05	279	470	330
CAE 2410YA-2	LBP	1/4	C.S.I.R.	LESS	-	312	-	1,065	7	0.25	5	8.00	254	450	340
CAE 2410YB	LBP	2/9	C.S.I.R.	WITH	270	-	921	-	13	0.32	5	9.05	279	470	330
CAE 2413YA	LBP	2/7	C.S.I.R.	LESS	330	-	1,126	-	13	0.32	5	9.05	279	470	330
CAE 2413YA-2	LBP	1/3	C.S.R.	LESS	-	372	-	1,269	13	0.32	5	9.05	279	470	330
CAE 2413YB	LBP	2/7	C.S.I.R.	WITH	330	-	1,126	-	13	0.32	5	9.05	279	470	330
CAE 2413YB-2	LBP	1/3	C.S.R.	WITH	-	372	-	1,269	13	0.32	5	9.05	279	470	330
CAE 2415YA	LBP	1/3	C.S.R.	LESS	370	-	1,262	-	13	0.32	5	9.05	279	470	330
CAE 2415YB	LBP	1/3	C.S.R.	WITH	370	-	1,262	-	13	0.32	5	9.05	279	470	330
CAE 3425YB-1	HBP	1/6	R.S.I.R.	WITH	-	802	-	1,958	13	0.32	5	9.00	279	470	330
CAE 4435YA	HBP	1/4	C.S.I.R.	LESS	902	-	3,078	-	7	0.22	5	8.00	254	450	340
CAE 4440YB-1	HBP	1/3	C.S.R.	WITH	-	1,174	-	4,006	7	0.53	5	9.00	284	470	330
CAE 4448YA	HBP	1/3	C.S.I.R.	LESS	1,190	-	4,060	-	7	0.22	5	8.00	336	500	435
CAE 7423YB	MBP	1/4	C.S.I.R.	WITH	574	-	1,958	-	13	0.32	5	9.00	279	470	330
CAE 7423YB-2	MBP	2/7	C.S.I.R.	WITH	-	670	-	2,286	13	0.32	5	9.00	279	470	330
CAE 7423YC	MBP	1/4	C.S.I.R.	WITH	574	-	1,958	-	13	0.32	5	9.00	279	470	330
CAE 7430YB	MBP	1/3	C.S.R.	WITH	745	-	2,542	-	13	0.32	5	9.00	279	470	330
CAE 7430YB-2	MBP	3/8	C.S.R.	WITH	-	866	-	2,955	13	0.32	5	9.00	279	470	330
CAE 7430YC	MBP	1/3	C.S.I.R.	WITH	745	-	2,542	-	13	0.32	5	9.00	279	470	330
CAE 9437YB	MBP	2/5	C.S.R.	WITH	920	-	3,139	-	13	0.32	5	9.00	279	470	330
	HBP	1/2			1,680	5,732									
CAE 9437YB-1	CBP	3/7	C.S.R.	WITH	-	986	-	3,363	13	0.32	5	9.05	279	470	330
CAE 9437YC	MBP	2/5	C.S.R.	WITH	920	-	3,139	-	13	0.32	5	9.00	279	470	330
	HBP	1/2			1,680	5,732									
CBA 9437YB	MBP	2/5	C.S.R.	WITH	920	-	3,139	-	28	0.60	5	11.80	319	550	435
	HBP	1/2			1,680	5,732									
CWJ 9440YB-1	CBP	1/2	C.S.R.	WITH	-	1,180	-	4,026	40	0.91	5	12.00	369	620	520
CWJ 9440YB-2	CBP	1/2	C.S.R.	WITH	-	1,158	-	3,951	40	0.91	5	12.00	369	620	520
CWJ 9460YB	CBP	2/3	C.S.R.	WITH	1,580	-	5,391	-	41	0.37	5	12.00	369	620	520
CAW 4515YB	MBP	2/3	C.S.R.	WITH	1,568	-	5,350	-	28	0.60	5	11.80	422	550	860
	HBP	1			3,526	12,031									
CAW 4517YB	MBP	1	C.S.R.	WITH	2,150	-	7,336	-	28	0.60	5	12.00	421	550	860
	HBP	1 2/9			4,298	14,665									
CAW 4519YB	MBP	4/7	C.S.R.	WITH	1,340	-	4,572	-	28	0.60	5	11.80	422	550	860
	HBP	7/8			3,090	10,543									
R404A/R507															
CAE 2420ZB-2	LBP	1/2	C.S.R.	WITH	-	575	-	1,962	13	0.32	5	9.05	279	470	330

CONDENSING UNIT

Model	App.	HP	Motor Type	Receiver Type	Nominal Capacity				Fan Motor		Fan Blade		Dimensions (mm.)		
					Watt		BTU/Hr		Output	FLA.	Blade	Diameter			
					50 Hz	60 Hz	50 Hz	60 Hz	Watt	Amps			inch (OD)	H	D
R404A/R507															
CAE 2425ZB-2	LBP	4/7	C.S.R.	WITH	-	670	-	2,286	13	0.32	5	9.05	279	470	330
CAE 4440ZB-1	HBP	3/8	C.S.R.	WITH	-	1,318	-	4,500	13	0.32	5	9.05	279	470	330
CWJ 2435ZB	LBP	5/7	C.S.R.	WITH	850	-	2,900	-	28	0.60	5	10.00	336	550	435
CWJ 2440ZB	LBP	5/6	C.S.R.	WITH	967	-	3,299	-	28	0.60	5	11.80	336	550	435
CWJ 2450ZB	LBP	1	C.S.R.	WITH	1,114	-	3,800	-	28	0.60	5	11.80	336	550	435
CWJ 2455ZA	LBP	1 1/6	C.S.R.	LESS	1,378	-	4,702	-	28	0.60	5	10.00	336	550	435
CWJ 2455ZA-A1	LBP	1 1/6	C.S.R.	LESS	1,378	-	4,702	-	28	0.60	5	11.80	336	550	435
CWJ 2455ZB	LBP	1 1/6	C.S.R.	WITH	1,378	-	4,702	-	28	0.60	5	12.00	336	550	435
CWJ 2435ZA	LBP	5/7	C.S.R.	LESS	850	-	2,900	-	28	0.60	5	10.00	336	550	435
CWJ 9485ZB	MBP	1	C.S.R.	WITH	2,180	-	7,438	-	41	0.37	5	11.80	336	550	435
	HBP	1			3,790		12,931								
CWJ 9490ZB	MBP	1	C.S.R.	WITH	2,345	-	8,001	-	28	0.60	5	11.80	336	550	435
	HBP	1 1/8			3,986		13,600								
CWJ 9490ZB-2	MBP	1 1/7	C.S.R.	WITH	-	2,696	-	9,200	40	0.91	5	11.80	336	550	435
	HBP	1 2/7				4,490		15,320							
CWJ 9513ZB	MBP	1 1/3	C.S.R.	WITH	3,157	-	10,770	-	28	0.60	5	11.80	336	550	435
	HBP	1 1/2			5,334		18,200								
CWJ 9513ZB-2	MBP	1 5/9	C.S.R.	WITH	-	3,650	-	12,454	40	0.91	5	12.00	319	500	435
	HBP	1 7/9				6,256		21,345							
CAW 2450ZB	LBP	1	C.S.R.	WITH	1,244	-	4,245	-	28	0.60	5	11.80	336	500	435
CAW 2462ZB	LBP	1 1/3	C.S.R.	WITH	1,525	-	5,203	-	28	0.60	5	11.80	422	550	860
CAW 2464ZB	LBP	1 1/3	C.S.R.	WITH	1,580	-	5,391	-	28	0.60	5	11.80	422	550	860
CAW 2464ZB-2	LBP	1 2/3	C.S.R.	WITH	-	1,938	-	6,612	40	0.91	5	11.80	337	500	635
CAW 2464ZB-9	LBP	1 3/7	3 PHASE	WITH	1,671	1,905	5,700	6,500	28	0.60	5	11.80	336	500	435
CAW 2495ZB	LBP	2	C.S.R.	WITH	2,322	-	7,923	-	28	0.60	5	11.80	396	550	860
CAW 2495ZB-9	LBP	2	3 PHASE	WITH	2,393	2,544	8,165	8,680	28	0.60	5	11.80	421	550	860
R22															
CAE 4448EB	HBP	1/3	C.S.R.	WITH	1,172	-	3,999	-	13	0.32	5	9.05	284	470	330
CAE 4474EB	HBP	1/3	C.S.R.	WITH	1,800	-	4,142	-	28	0.60	5	11.80	336	500	435
CAE 7422EB	MBP	1/4	C.S.I.R.	WITH	550	-	1,877	-	7	0.22	5	9.05	279	470	330
CAE 7435EA	MBP	3/8	C.S.R.	LESS	870	-	2,968	-	7	0.32	5	9.00	279	470	330
CAE 7435EB	MBP	3/8	C.S.R.	WITH	870	-	2,968	-	13	0.32	5	9.05	279	470	330
CAE 7440EB	MBP	3/7	C.S.R.	WITH	1,010	-	3,446	-	13	0.32	5	9.00	284	470	330
CAE 7440EC	MBP	3/7	C.S.R.	WITH	1,010	-	3,446	-	7	1.22	5	8.00	279	470	330
CWJ 9480EB	CBP	4/5	C.S.R.	WITH	1,900	-	6,483	-	41	0.37	5	11.80	369	620	520
CAW 5522EB-9	HBP	1 1/2	3 PHASE	WITH	5,143	6,213	17,548	21,199	41	0.37	5	11.80	421	550	860
CAW 5524EB-9	HBP	1 2/3	3 PHASE	WITH	5,802	6,909	19,795	23,572	28	0.60	5	11.80	421	550	860
CAW 5524EC	HBP	1 3/4	PSC	WITH	6,140	-	20,950	-	28	0.60	5	10.00	336	550	435

CONDENSING UNIT

Model	App.	HP	Motor Type	Receiver Type	Nominal Capacity				Fan Motor		Fan Blade		Dimensions (mm.)		
					Watt		BTU/Hr		Output	FLA.	Blade	Diameter inch (OD)			
					50 Hz	60 Hz	50 Hz	60 Hz	Watt	Amps			H	D	W
R22															
CAW 5528EB-9	HBP	2	3 PHASE	WITH	6,800	8,270	23,202	28,217	28	0.60	5	11.80	421	550	860
CAW 5530EC	HBP	2	PSC	WITH	7,327	-	25,000	-	28	0.60	5	12.00	421	550	860
R407C															
CWJ 9470GB	CBP	5/7	C.S.R.	WITH	1,700	-	5,800	-	28	0.60	5	11.80	369	620	520
CWJ 9485GB	CBP	1	C.S.R.	WITH	2,140	-	7,302	-	41	0.37	5	11.80	446	620	520
CAW 4520GB	MBP	1 1/8	C.S.R.	WITH	2,643	-	9,018	-	28	0.60	5	11.80	422	550	860
	HBP	1 1/2			5,200										
CAW 4524GB	MBP	1 1/3	C.S.R.	WITH	3,116	-	10,632	-	28	0.60	5	11.80	422	550	860
	HBP	1 3/4			6,140										
CAW 4528GB	MBP	1 5/9	C.S.R.	WITH	3,633	-	12,396	-	28	0.60	5	11.80	421	550	860
	HBP	2			7,108										
CAW 4532GB	MBP	1 3/4	C.S.R.	WITH	4,050	-	13,819	-	28	0.60	5	11.80	396	550	860
	HBP	2 1/4			7,870										

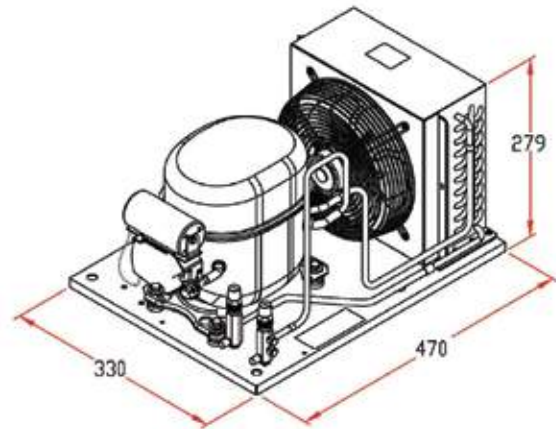
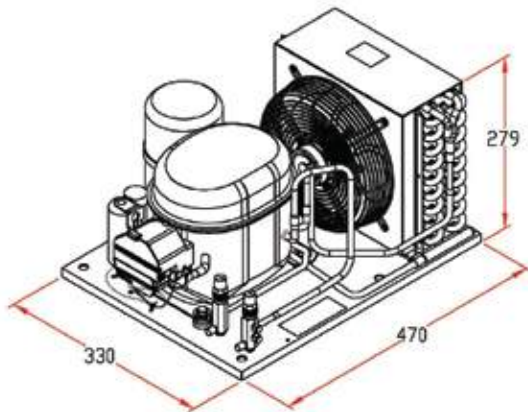

▶ **RSIR: Resistance Start Induction Run**

The motors have a normal starting torque and are designed for completely self-equalizing capillary tube.

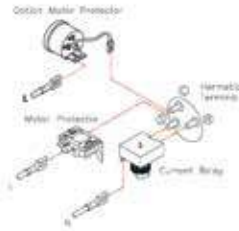

▶ **RSCR: Resistance Start Capacitor Run**

The motors have a PTC starting and run capacitor. Their functioning is similar to the PSC motor. These compressors have a normal starting torque

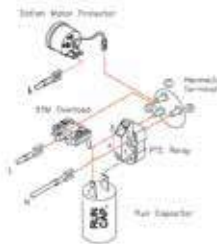

▶ **CSIR: Capacitor Start Induction Run**

The motors have a high starting torque, using an electrolytic starting capacitor. Recommended for application with capillary tube or expansion valve system.

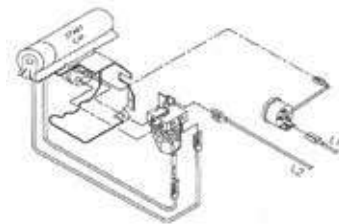

▶ **PSC: Permanent Split Capacitor**

A run capacitor in series with the start winding produces a higher efficiency in comparison to a RSIR motor. They a normal starting torque and are designed for capillary tube control device, with equalized pressures.

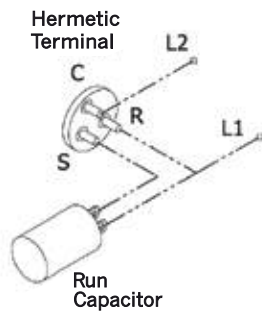

▶ **3 Phase Motor**

Excellent starting torque, a wide operating voltage range, no ancillary starting devices (relay, capacitor), reduced starting load on any individual phase and minimal impact on nearby lighting, etc.

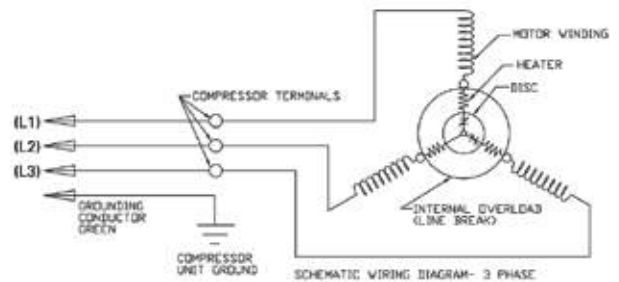

▶ **CSR: Capacitor Start Capacitor Run**

This motor arrangement uses a start capacitor added to a PSC circuit. The high starting torque is suitable for unequalized systems with capillary tube or expansion valve, maintaining the same efficiency of a PSC motor.

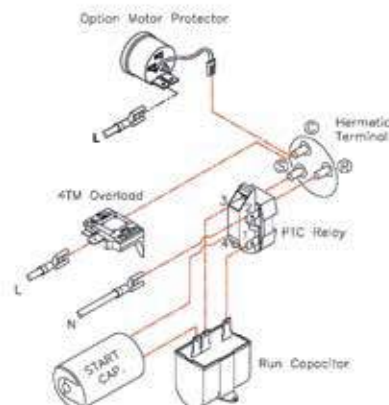
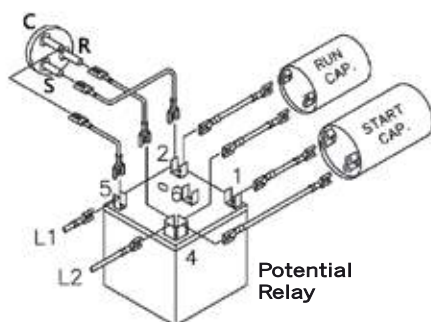

ELECTRICAL TERMINAL BOX

Rating Conditions (ASHRAE-T) for All Series

	LBP	MBP/CBP	HBP/AC
- Evaporating Temp.	-10°F / -23.3°C	20°F / -6.7°C	45°F / 7.2°C
- Condensing Temp.	130°F / 54.4°C	130°F / 54.4°C	130°F / 54.4°C
- Return Gas Temp.	90°F / 32°C	95°F / 35°C	95°F / 35°C
- Liquid entering Temp.	90°F / 32°C	115°F / 46°C	115°F / 46°C
- Room Ambient	90°F / 32°C	95°F / 35°C	95°F / 35°C
- Application Range	-34 to -12°C (-29 to 10°F)	-23 to 12.7°C (-9.4 to 55°F)	-6.7 to 12.7°C (20 to 55°F)

Compressor Mounting System

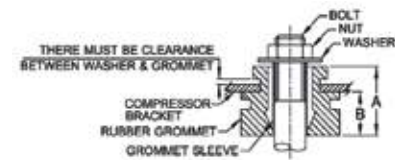

Type A

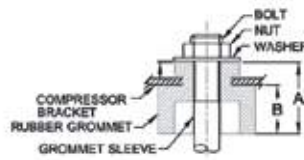

Type C

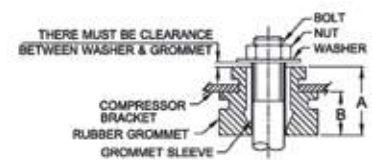

Type D

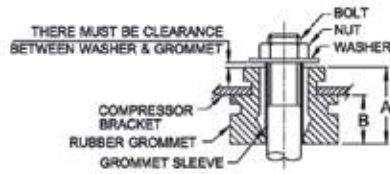

Type E

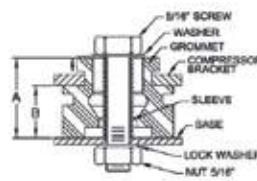

Type F

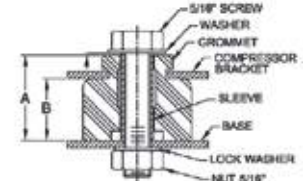

Type G

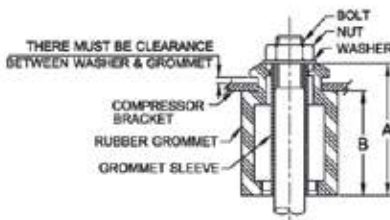

Type H

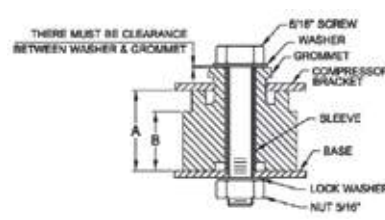

Type I

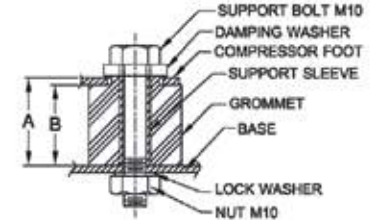

Type J

Type	High "A" (mm.)	High "B" (mm.)
A	17.5	9.5
C	22	15
D	21.8	13.9
E	19.05	11.12
F	23.02	15.08
G	28.9	20.7
H	37	29
I	36.5	28.5
J	39	35

GENERAL DIMENSIONS (mm.)

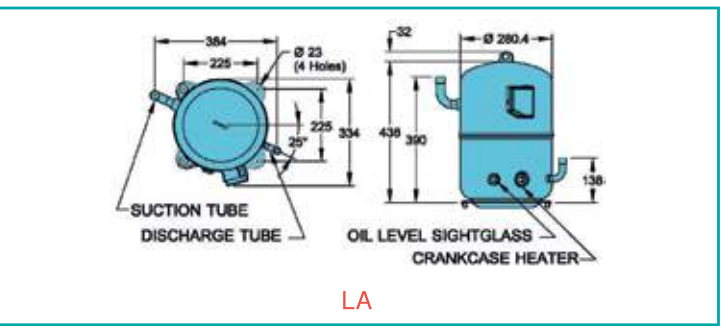
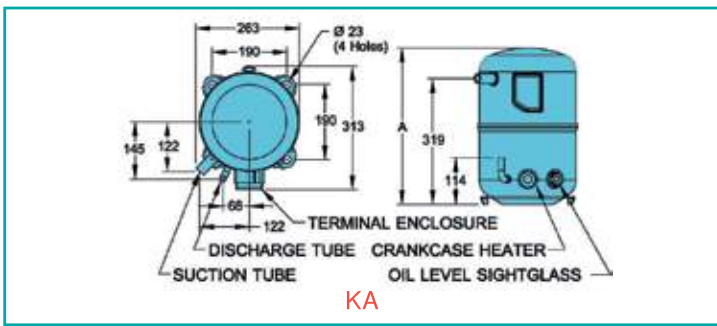
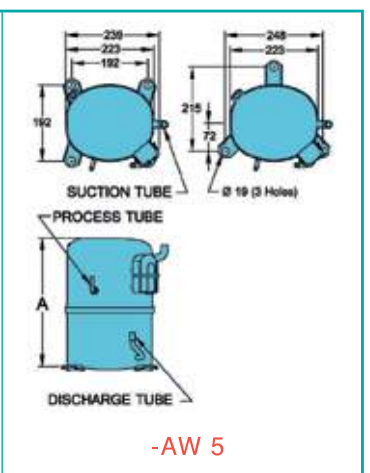
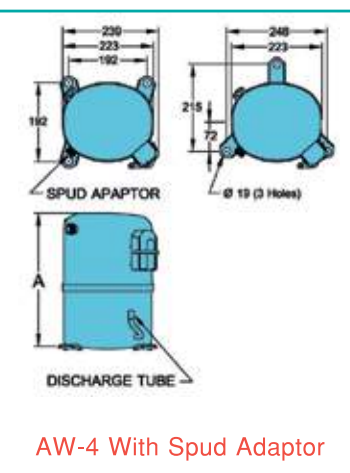
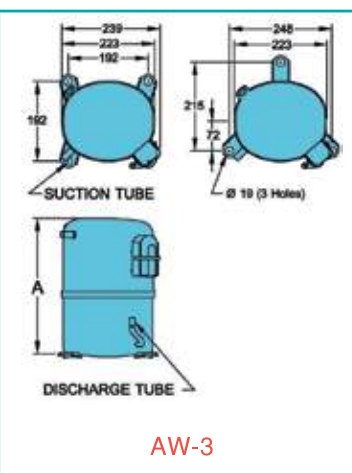
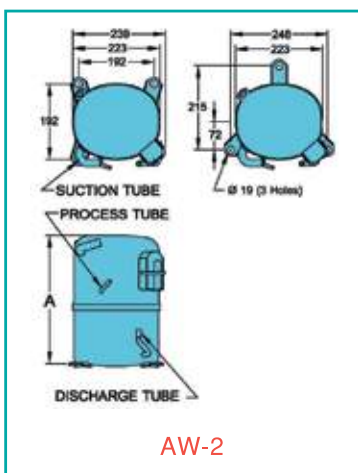
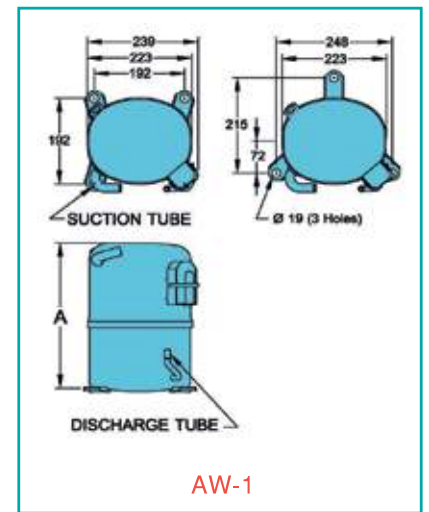
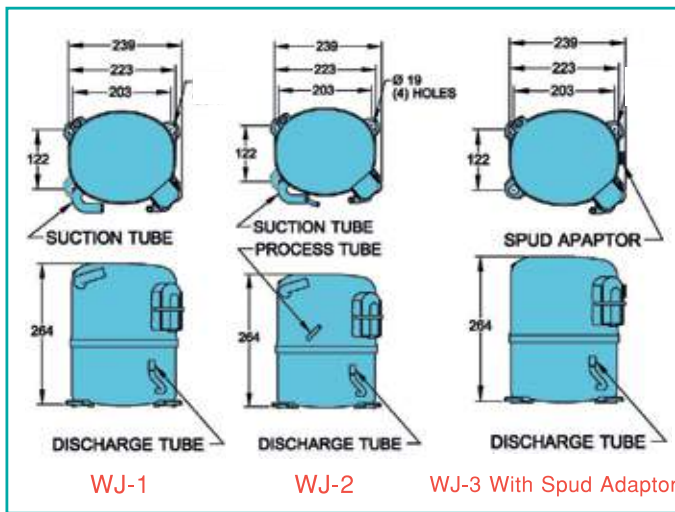
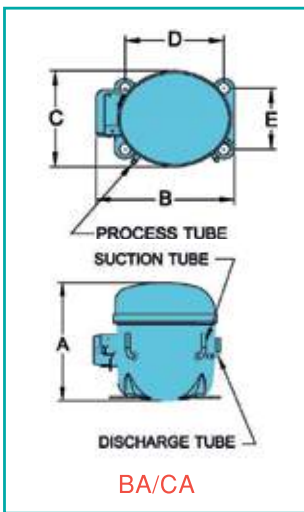
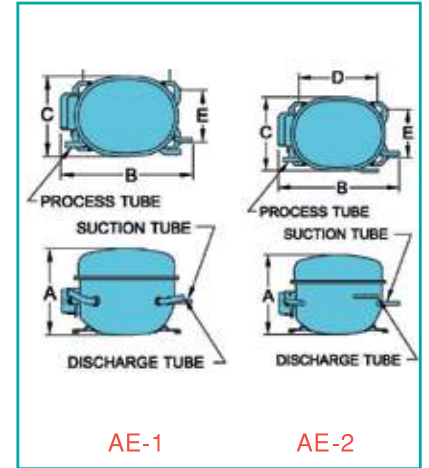
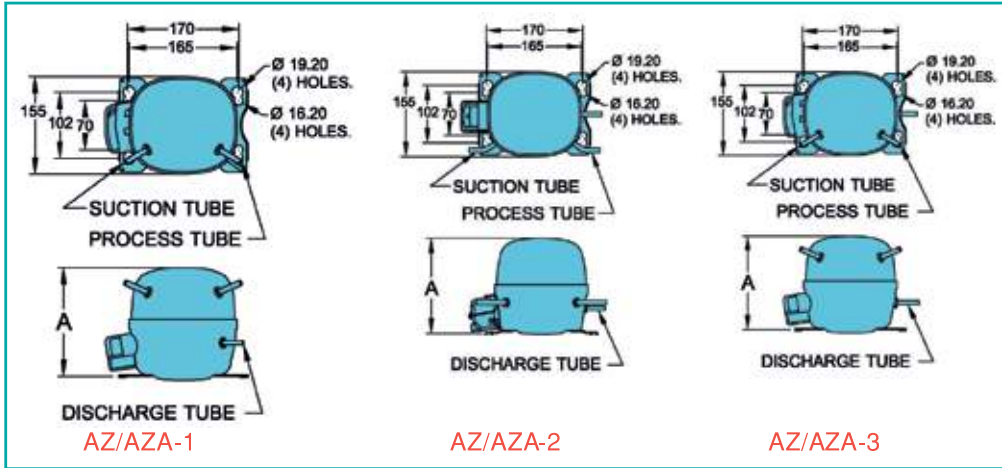

Models	power (HP)	App.	Disp. (cc)	Cooling (w)		Cooling (Btu)		COP (w/w)		EER (Btu/w)		Motor type	Cooling		Start Cap		Run Cap		Dim. "height"
				50 Hz	60 Hz	50 Hz	60 Hz	50 Hz	60 Hz	50 Hz	60 Hz		Type	mF	vac	mF	vac		
C-QN Series (High Performance)																			R134a
1A7:S4200V / 50Hz, 60Hz.																			
C-QN30L0*	1/25	LBP	1.79	31	40	106	137	0.66	0.80	2.25	2.73	RSCR	N	**	**	3-5	200	154	
C-QN40L0*	1/19	LBP	2.13	45	53	154	181	0.77	0.90	2.63	3.07	RSCR	N	**	**	3-5	200	154	
C-QN50L0*	1/15	LBP	2.45	56	67	191	229	0.96	1.00	3.28	3.41	RSCR	N	**	**	3-5	200	167	
C-QN60L0*	1/12	LBP	2.77	65	78	222	266	0.98	1.08	3.34	3.69	RSCR	N	**	**	3-5	200	167	
C-QN75L0*	1/10	LBP	3.58	83	101	283	345	1.05	1.12	3.58	3.82	RSCR	N	**	**	3-5	200	177	
C-QN90L0*	1/8	LBP	3.92	93	113	317	386	1.10	1.16	3.75	3.96	RSCR	N	**	**	3-5	200	177	
C-QN100L0*	1/7	LBP	4.36	103	125	352	427	1.15	1.17	3.92	3.99	RSCR	N	**	**	3-5	200	177	
100V / 50Hz., 115-127V / 60Hz.																			
C-QN30L2*	1/25	LBP	1.79	31	40	106	137	0.68	0.83	2.32	2.83	RSCR	N	**	**	8-10	200	154	
C-QN40L2*	1/19	LBP	2.13	45	53	154	181	0.90	0.93	3.07	3.17	RSCR	N	**	**	8-10	200	154	
C-QN50L2*	1/15	LBP	2.45	56	67	191	229	0.98	1.04	3.34	3.55	RSCR	N	**	**	8-10	200	167	
C-QN60L2*	1/12	LBP	2.77	65	78	222	266	1.00	1.10	3.41	3.75	RSCR	N	**	**	8-10	200	167	
C-QN75L2*	1/10	LBP	3.58	83	101	283	345	1.10	1.13	3.75	3.86	RSCR	N	**	**	8-10	200	177	
C-QN90L2*	1/8	LBP	3.92	93	113	317	386	1.15	1.18	3.92	4.03	RSCR	N	**	**	8-10	200	177	
C-QN100L2*	1/7	LBP	4.36	103	125	352	427	1.17	1.20	3.99	4.10	RSCR	N	**	**	8-10	200	177	
220-240V / 50Hz.																			
C-QN30L5*	1/25	LBP	1.79	31	**	106	**	0.68	**	2.32	**	RSCR	N	**	**	3-5	350	154	
C-QN40L5*	1/19	LBP	2.13	45	**	154	**	0.90	**	3.07	**	RSCR	N	**	**	3-5	350	154	
C-QN50L5*	1/15	LBP	2.45	56	**	191	**	0.98	**	3.34	**	RSCR	N	**	**	3-5	350	167	
C-QN60L5*	1/12	LBP	2.77	65	**	222	**	1.00	**	3.41	**	RSCR	N	**	**	3-5	350	167	
C-QN75L5*	1/10	LBP	3.58	83	**	283	**	1.10	**	3.75	**	RSCR	N	**	**	3-5	350	177	
C-QN90L5*	1/8	LBP	3.92	93	**	317	**	1.15	**	3.92	**	RSCR	N	**	**	3-5	350	177	
C-QN100L5*	1/7	LBP	4.36	103	**	352	**	1.17	**	3.99	**	RSCR	N	**	**	3-5	350	177	
200-220V / 50Hz., 220V / 60Hz.																			
C-QN30L6*	1/25	LBP	1.79	31	40	106	137	0.68	0.83	2.32	2.83	RSCR	N	**	**	3-5	350	154	
C-QN40L6*	1/19	LBP	2.13	45	53	154	181	0.90	0.93	3.07	3.17	RSCR	N	**	**	3-5	350	154	
C-QN50L6*	1/15	LBP	2.45	56	67	191	229	0.98	1.04	3.34	3.55	RSCR	N	**	**	3-5	350	167	
C-QN60L6*	1/12	LBP	2.77	65	78	222	266	1.00	1.10	3.41	3.75	RSCR	N	**	**	3-5	350	167	
C-QN75L6*	1/10	LBP	3.58	83	101	283	345	1.10	1.13	3.75	3.86	RSCR	N	**	**	3-5	350	177	
C-QN90L6*	1/8	LBP	3.92	93	113	317	386	1.15	1.18	3.92	4.03	RSCR	N	**	**	3-5	350	177	
C-QN100L6*	1/7	LBP	4.36	103	125	352	427	1.17	1.20	3.99	4.10	RSCR	N	**	**	3-5	350	177	

C-Q Type (RSCR)

Models	Power (HP)	App.	Disp. (cc)	Cooling (w)		Cooling (Btu)		COP (w/w)		EER (Btu/w)		Motor type	Cooling		Start Cap		Run Cap		Dim. "height"
				50 Hz	60 Hz	50 Hz	60 Hz	50 Hz	60 Hz	50 Hz	60 Hz		Type	mF	vac	mF	vac		
C-QE Series (High Performance)																			R134a
100V / 50Hz, 60Hz.																			
C-QE50L0*	1/15	LBP	1.79	50	60	171	205	1.27	1.28	4.33	4.37	RSCR	N	**	**	3-5	200	154	
C-QE60L0*	1/12	LBP	2.13	60	72	205	246	1.27	1.28	4.33	4.37	RSCR	N	**	**	3-5	200	154	
C-QE75L0*	1/10	LBP	2.45	72	86	246	295	1.29	1.30	4.40	4.44	RSCR	N	**	**	3-5	200	167	
C-QE80L0*	1/10	LBP	2.77	80	96	273	328	1.29	1.30	4.40	4.44	RSCR	N	**	**	3-5	200	167	
C-QE90L0*	1/8	LBP	2.92	85	102	290	348	1.31	1.33	4.47	4.54	RSCR	N	**	**	3-5	200	167	
C-QE95L0*	1/8	LBP	3.28	95	114	324	389	1.32	1.35	4.50	4.61	RSCR	N	**	**	3-5	200	167	
C-QE100L0*	1/7	LBP	3.58	105	126	358	430	1.35	1.38	4.61	4.71	RSCR	N	**	**	3-5	200	167	
C-QE110L0*	1/7	LBP	3.92	115	138	392	471	1.38	1.40	4.71	4.78	RSCR	N	**	**	3-5	200	177	
C-QE120L0*	1/6	LBP	4.36	125	150	427	512	1.38	1.40	4.71	4.78	RSCR	N	**	**	3-5	200	177	
100V / 50Hz., 115-127V / 60Hz.																			
C-QE50L2*	1/15	LBP	1.79	50	60	171	205	1.30	1.31	4.44	4.47	RSCR	N	**	**	8-10	200	154	
C-QE60L2*	1/12	LBP	2.13	60	72	205	246	1.32	1.33	4.50	4.54	RSCR	N	**	**	8-10	200	154	
C-QE75L2*	1/10	LBP	2.45	72	86	246	295	1.32	1.33	4.50	4.54	RSCR	N	**	**	8-10	200	167	
C-QE80L2*	1/10	LBP	2.77	80	96	273	328	1.35	1.37	4.61	4.68	RSCR	N	**	**	8-10	200	167	
C-QE90L2*	1/8	LBP	2.92	85	102	290	348	1.35	1.37	4.61	4.68	RSCR	N	**	**	8-10	200	167	
C-QE95L2*	1/8	LBP	3.28	95	114	324	389	1.38	1.39	4.71	4.74	RSCR	N	**	**	8-10	200	167	
C-QE100L2*	1/7	LBP	3.58	105	126	358	430	1.41	1.42	4.81	4.85	RSCR	N	**	**	8-10	200	167	
C-QE110L2*	1/7	LBP	3.92	115	138	392	471	1.43	1.44	4.88	4.91	RSCR	N	**	**	8-10	200	177	
C-QE120L2*	1/6	LBP	4.36	125	150	427	512	1.43	1.44	4.88	4.91	RSCR	N	**	**	8-10	200	177	
220-240V / 50Hz.																			
C-QE50L5*	1/15	LBP	1.79	50	**	171	**	1.30	**	4.44	**	RSCR	N	**	**	3-5	350	154	
C-QE60L5*	1/12	LBP	2.13	60	**	205	**	1.32	**	4.50	**	RSCR	N	**	**	3-5	350	154	
C-QE75L5*	1/10	LBP	2.45	72	**	246	**	1.32	**	4.50	**	RSCR	N	**	**	3-5	350	167	
C-QE80L5*	1/10	LBP	2.77	80	**	273	**	1.35	**	4.61	**	RSCR	N	**	**	3-5	350	167	
C-QE90L5*	1/8	LBP	2.92	85	**	290	**	1.35	**	4.61	**	RSCR	N	**	**	3-5	350	167	
C-QE95L5*	1/8	LBP	3.28	95	**	324	**	1.38	**	4.71	**	RSCR	N	**	**	3-5	350	167	
C-QE100L5*	1/7	LBP	3.58	105	**	358	**	1.41	**	4.81	**	RSCR	N	**	**	3-5	350	167	
C-QE110L5*	1/7	LBP	3.92	115	**	392	**	1.43	**	4.88	**	RSCR	N	**	**	3-5	350	177	
C-QE120L5*	1/6	LBP	4.36	125	**	427	**	1.43	**	4.88	**	RSCR	N	**	**	3-5	350	177	

Models	Power (HP)	App.	Disp. (cc)	Cooling (w)		Cooling (Btu)		COP (w/w)		EER (Btu/w)		Motor type	Cooling Type	Start Cap		Run Cap		Dim. "height"
				50 Hz	60 Hz	50 Hz	60 Hz	50 Hz	60 Hz	50 Hz	60 Hz			mF	vac	mF	vac	
C-QE Series (High Performance)																		R134a
200-220V / 50Hz., 220V / 60Hz.																		
C-QE50L6*	1/15	LBP	1.79	50	60	171	205	1.30	1.31	4.44	4.47	RSCR	N	**	**	3-5	350	154
C-QE60L6*	1/12	LBP	2.13	60	72	205	246	1.32	1.33	4.50	4.54	RSCR	N	**	**	3-5	350	154
C-QE75L6*	1/10	LBP	2.45	72	86	246	295	1.32	1.33	4.50	4.54	RSCR	N	**	**	3-5	350	167
C-QE80L6*	1/10	LBP	2.77	80	96	273	328	1.35	1.37	4.61	4.68	RSCR	N	**	**	3-5	350	167
C-QE90L6*	1/8	LBP	2.92	85	102	290	348	1.35	1.37	4.61	4.68	RSCR	N	**	**	3-5	350	167
C-QE95L6*	1/8	LBP	3.28	95	114	324	389	1.38	1.39	4.71	4.74	RSCR	N	**	**	3-5	350	167
C-QE100L6*	1/7	LBP	3.58	105	126	358	430	1.41	1.42	4.81	4.85	RSCR	N	**	**	3-5	350	167
C-QE110L6*	1/7	LBP	3.92	115	138	392	471	1.43	1.44	4.88	4.91	RSCR	N	**	**	3-5	350	177
C-QE120L6*	1/6	LBP	4.36	125	150	427	512	1.43	1.44	4.88	4.91	RSCR	N	**	**	3-5	350	177

C-Q Type

Models	Power (HP)	App.	Disp. (cc)	Cooling (w)		Cooling (Btu)		COP (w/w)		EER (Btu/w)		Motor type	Cooling Type	Start Cap		Run Cap		Dim. "H1"
				50 Hz	60 Hz	50 Hz	60 Hz	50 Hz	60 Hz	50 Hz	60 Hz			mF	vac	mF	vac	
C-QH Series (Standard Performance)																		R600a
100V / 50Hz, 60Hz.																		
C-QH25L0*	1/30	LBP	1.79	30	35	101	119	1.25	1.27	4.27	4.33	RSCR	N	**	**	3-12	200	154
C-QH30L0*	1/25	LBP	2.13	35	41	121	141	1.28	1.29	4.37	4.40	RSCR	N	**	**	3-12	200	154
C-QH35L0*	1/22	LBP	2.45	41	48	139	162	1.28	1.30	4.37	4.44	RSCR	N	**	**	3-12	200	167
C-QH40L0*	1/19	LBP	2.77	46	54	157	183	1.30	1.30	4.44	4.44	RSCR	N	**	**	3-12	200	167
C-QH50L0*	1/15	LBP	3.58	59	69	203	237	1.30	1.31	4.44	4.47	RSCR	N	**	**	3-12	200	177
C-QH60L0*	1/12	LBP	3.92	65	76	222	260	1.33	1.31	4.54	4.47	RSCR	N	**	**	3-12	200	177
C-QH75L0*	1/10	LBP	4.36	72	85	247	289	1.33	1.31	4.54	4.47	RSCR	N	**	**	3-12	200	177
100V / 50Hz., 115-127V / 60Hz.																		
C-QH25L2*	1/30	LBP	1.79	30	35	101	119	1.25	1.30	4.27	4.44	RSCR	N	**	**	3-5	200	154
C-QH30L2*	1/25	LBP	2.13	35	41	121	141	1.28	1.32	4.37	4.50	RSCR	N	**	**	3-5	200	154
C-QH35L2*	1/22	LBP	2.45	41	48	139	162	1.28	1.32	4.37	4.50	RSCR	N	**	**	3-5	200	167
C-QH40L2*	1/19	LBP	2.77	46	54	157	183	1.30	1.34	4.44	4.57	RSCR	N	**	**	3-5	200	167
C-QH50L2*	1/15	LBP	3.58	59	69	203	237	1.30	1.34	4.44	4.57	RSCR	N	**	**	3-5	200	177
C-QH60L2*	1/12	LBP	3.92	65	76	222	260	1.33	1.35	4.54	4.61	RSCR	N	**	**	3-5	200	177
C-QH75L2*	1/10	LBP	4.36	72	85	247	289	1.33	1.35	4.54	4.61	RSCR	N	**	**	3-5	200	177
220-240V / 50Hz.																		
C-QH25L5*	1/30	LBP	1.79	30	**	101	**	1.25	**	4.27	**	RSCR	N	**	**	3-5	350	154
C-QH30L5*	1/25	LBP	2.13	35	**	121	**	1.28	**	4.37	**	RSCR	N	**	**	3-5	350	154
C-QH35L5*	1/22	LBP	2.45	41	**	139	**	1.28	**	4.37	**	RSCR	N	**	**	3-5	350	167
C-QH40L5*	1/19	LBP	2.77	46	**	157	**	1.30	**	4.44	**	RSCR	N	**	**	3-5	350	167
C-QH50L5*	1/15	LBP	3.58	59	**	203	**	1.30	**	4.44	**	RSCR	N	**	**	3-5	350	177
C-QH60L5*	1/12	LBP	3.92	65	**	222	**	1.33	**	4.54	**	RSCR	N	**	**	3-5	350	177
C-QH75L5*	1/10	LBP	4.36	72	**	247	**	1.33	**	4.54	**	RSCR	N	**	**	3-5	350	177
200-220V / 50Hz., 220V / 60Hz.																		
C-QH25L6*	1/30	LBP	1.79	30	35	101	119	1.25	1.30	4.27	4.44	RSCR	N	**	**	3-5	350	154
C-QH30L6*	1/25	LBP	2.13	35	41	121	141	1.28	1.32	4.37	4.50	RSCR	N	**	**	3-5	350	154
C-QH35L6*	1/22	LBP	2.45	41	48	139	162	1.28	1.32	4.37	4.50	RSCR	N	**	**	3-5	350	167
C-QH40L6*	1/19	LBP	2.77	46	54	157	183	1.30	1.34	4.44	4.57	RSCR	N	**	**	3-5	350	167
C-QH50L6*	1/15	LBP	3.58	59	69	203	237	1.30	1.34	4.44	4.57	RSCR	N	**	**	3-5	350	177
C-QH60L6*	1/12	LBP	3.92	65	76	222	260	1.33	1.35	4.54	4.61	RSCR	N	**	**	3-5	350	177
C-QH75L6*	1/10	LBP	4.36	72	85	247	289	1.33	1.35	4.54	4.61	RSCR	N	**	**	3-5	350	177

C-B Type

Models	Power (HP)	App.	Disp. (cc)	Cooling (w)		Cooling (Btu)		COP (w/w)		EER (Btu/w)		Motor type	Cooling Type	Start Cap		Run Cap		Dim. "H1"
				50 Hz	60 Hz	50 Hz	60 Hz	50 Hz	60 Hz	50 Hz	60 Hz			mF	vac	mF	vac	
C-BZN Series (Standard Performance)																		R134a
100V / 50Hz, 60Hz.																		
C-BZN100L0*	1/8	LBP	4.50	109	131	372	447	1.14	1.19	3.89	4.06	RSIR/CSIR	N	75	125	**	**	175
C-BZN110L0*	1/7	LBP	5.20	142	170	485	580	1.20	1.24	4.10	4.23	RSIR/CSIR	N	75	125	**	**	175
C-BZN120L0*	1/6	LBP	5.70	156	190	532	648	1.23	1.25	4.20	4.27	RSIR/CSIR	N	75	125	**	**	188
C-BZN140L0*	1/6	LBP	6.08	170	194	580	662	1.25	1.27	4.27	4.33	RSIR/CSIR	N	75	125	**	**	188
C-BZN150L0*	1/5	LBP	6.65	192	232	655	792	1.27	1.29	4.33	4.40	RSIR/CSIR	N	75	125	**	**	188
C-BZN175L0*	1/5	LBP	7.24	210	247	717	843	1.30	1.31	4.44	4.47	RSIR/CSIR	F/O	75	125	**	**	195
C-BZN200L0*	1/4	LBP	8.37	242	295	826	1,007	1.32	1.33	4.50	4.54	RSIR/CSIR	F/O	75	125	**	**	195
C-BZN225L0*	1/3	LBP	9.03	261	318	891	1,086	1.33	1.35	4.54	4.61	RSIR/CSIR	F/O	75	125	**	**	198
C-BZN250L0*	1/3	LBP	9.82	284	346	969	1,181	1.33	1.35	4.54	4.61	RSIR/CSIR	F/O	75	125	**	**	198
100V / 50Hz., 115-127V / 60Hz.																		
C-BZN100L2*	1/8	LBP	4.50	109	131	372	447	1.14	1.19	3.89	4.06	RSIR/CSIR	N	100	125	**	**	175

Models	Power (HP)	App.	Disp. (cc)	Cooling (w)		Cooling (Btu)		COP (w/w)		EER (Btu/w)		Motor type	Cooling Type	Start Cap		Run Cap		Dim. "H1"	
				50 Hz	60 Hz	50 Hz	60 Hz	50 Hz	60 Hz	50 Hz	60 Hz			mF	vac	mF	vac		
C-BZN Series (Standard Performance)																			R134a
100V / 50Hz., 115-127V / 60Hz.																			
C-BZN110L2*	1/7	LBP	5.20	142	170	485	580	1.20	1.24	4.10	4.23	RSIR/CSIR	N	100	125	**	**	175	
C-BZN120L2*	1/6	LBP	5.70	156	190	532	648	1.23	1.25	4.20	4.27	RSIR/CSIR	N	100	125	**	**	188	
C-BZN140L2*	1/6	LBP	6.08	170	194	580	662	1.25	1.27	4.27	4.33	RSIR/CSIR	N	100	125	**	**	188	
C-BZN150L2*	1/5	LBP	6.65	192	232	655	792	1.27	1.29	4.33	4.40	RSIR/CSIR	N	100	125	**	**	188	
C-BZN175L2*	1/5	LBP	7.24	210	247	717	843	1.30	1.31	4.44	4.47	RSIR/CSIR	F/O	100	125	**	**	195	
C-BZN200L2*	1/4	LBP	8.37	242	295	826	1,007	1.32	1.33	4.50	4.54	RSIR/CSIR	F/O	100	125	**	**	195	
C-BZN225L2*	1/3	LBP	9.03	261	318	891	1,086	1.33	1.35	4.54	4.61	RSIR/CSIR	F/O	100	125	**	**	198	
C-BZN250L2*	1/3	LBP	9.82	284	346	969	1,181	1.33	1.35	4.54	4.61	RSIR/CSIR	F/O	100	125	**	**	198	
220-240V / 50Hz.																			
C-BZN100L5*	1/8	LBP	4.50	109	**	372	**	1.14	**	3.89	**	RSIR/CSIR	N	40	160	**	**	175	
C-BZN110L5*	1/7	LBP	5.20	142	**	485	**	1.20	**	4.10	**	RSIR/CSIR	N	40	160	**	**	175	
C-BZN120L5*	1/6	LBP	5.70	156	**	532	**	1.23	**	4.20	**	RSIR/CSIR	N	40	160	**	**	188	
C-BZN140L5*	1/6	LBP	6.08	170	**	580	**	1.25	**	4.27	**	RSIR/CSIR	N	40	160	**	**	188	
C-BZN150L5*	1/5	LBP	6.65	192	**	655	**	1.27	**	4.33	**	RSIR/CSIR	N	40	160	**	**	188	
C-BZN175L5*	1/5	LBP	7.24	210	**	717	**	1.30	**	4.44	**	RSIR/CSIR	F/O	40	160	**	**	195	
C-BZN200L5*	1/4	LBP	8.37	242	**	826	**	1.32	**	4.50	**	RSIR/CSIR	F/O	40	160	**	**	195	
C-BZN225L5*	1/3	LBP	9.03	261	**	891	**	1.33	**	4.54	**	RSIR/CSIR	F/O	40	160	**	**	198	
C-BZN250L5*	1/3	LBP	9.82	284	**	969	**	1.33	**	4.54	**	RSIR/CSIR	F/O	40	160	**	**	198	
200-220V / 50Hz., 220V / 60Hz.																			
C-BZN100L6*	1/8	LBP	4.50	109	131	372	447	1.14	1.19	3.89	4.06	RSIR/CSIR	N	40	160	**	**	175	
C-BZN110L6*	1/7	LBP	5.20	142	170	485	580	1.20	1.24	4.10	4.23	RSIR/CSIR	N	40	160	**	**	175	
C-BZN120L6*	1/6	LBP	5.70	156	190	532	648	1.23	1.25	4.20	4.27	RSIR/CSIR	N	40	160	**	**	188	
C-BZN140L6*	1/6	LBP	6.08	170	194	580	662	1.25	1.27	4.27	4.33	RSIR/CSIR	N	40	160	**	**	188	
C-BZN150L6*	1/5	LBP	6.65	192	232	655	792	1.27	1.29	4.33	4.40	RSIR/CSIR	N	40	160	**	**	188	
C-BZN175L6*	1/5	LBP	7.24	210	247	717	843	1.30	1.31	4.44	4.47	RSIR/CSIR	F/O	40	160	**	**	195	
C-BZN200L6*	1/4	LBP	8.37	242	295	826	1,007	1.32	1.33	4.50	4.54	RSIR/CSIR	F/O	40	160	**	**	195	
C-BZN225L6*	1/3	LBP	9.03	261	318	891	1,086	1.33	1.35	4.54	4.61	RSIR/CSIR	F/O	40	160	**	**	198	
C-BZN250L6*	1/3	LBP	9.82	284	346	969	1,181	1.33	1.35	4.54	4.61	RSIR/CSIR	F/O	40	160	**	**	198	

C-B Type

Models	Power (HP)	App.	Disp. (cc)	Cooling (w)		Cooling (Btu)		COP (w/w)		EER (Btu/w)		Motor type	Cooling Type	Start Cap		Run Cap		Dim. "H1"	
				50 Hz	60 Hz	50 Hz	60 Hz	50 Hz	60 Hz	50 Hz	60 Hz			mF	vac	mF	vac		
C-BE Series (High Performance)																			R134a
100V / 50Hz, 60Hz.																			
C-BE100L0*	1/8	LBP	4.50	113	150	386	512	1.40	1.46	4.78	4.98	CSR/RSCR	N	75	160	12	180	175	
C-BE110L0*	1/7	LBP	5.20	151	180	515	614	1.42	1.53	4.85	5.22	CSR/RSCR	N	75	160	12	180	175	
C-BE120L0*	1/6	LBP	5.70	162	196	553	669	1.41	1.55	4.81	5.29	CSR/RSCR	N	75	160	12	180	188	
C-BE140L0*	1/6	LBP	6.08	180	214	614	730	1.59	1.64	5.43	5.60	CSR/RSCR	N	75	160	12	180	188	
C-BE150L0*	1/5	LBP	6.65	195	235	665	802	1.59	1.64	5.43	5.60	CSR/RSCR	N	75	160	12	180	188	
C-BE175L0*	1/5	LBP	7.24	220	260	751	887	1.53	1.58	5.22	5.39	CSR/RSCR	F/O	75	160	12	180	195	
C-BE200L0*	1/4	LBP	8.37	255	306	870	1,044	1.53	1.58	5.22	5.39	CSR/RSCR	F/O	75	160	12	180	195	
C-BE225L0*	1/3	LBP	9.03	275	330	939	1,127	1.55	1.60	5.29	5.46	CSR/RSCR	F/O	75	160	12	180	198	
C-BE250L0*	1/3	LBP	9.82	299	359	1,021	1,225	1.55	1.60	5.29	5.46	CSR/RSCR	F/O	75	160	12	180	198	
100V / 50Hz., 115-127V / 60Hz.																			
C-BE100L2*	1/8	LBP	4.50	113	150	386	512	1.40	1.46	4.78	4.98	CSR/RSCR	N	75	160	14	220	175	
C-BE110L2*	1/7	LBP	5.20	151	180	515	614	1.42	1.53	4.85	5.22	CSR/RSCR	N	75	160	14	220	175	
C-BE120L2*	1/6	LBP	5.70	162	196	553	669	1.41	1.55	4.81	5.29	CSR/RSCR	N	75	160	14	220	188	
C-BE140L2*	1/6	LBP	6.08	180	214	614	730	1.59	1.64	5.43	5.60	CSR/RSCR	N	75	160	14	220	188	
C-BE150L2*	1/5	LBP	6.65	195	235	665	802	1.59	1.64	5.43	5.60	CSR/RSCR	N	75	160	14	220	188	
C-BE175L2*	1/5	LBP	7.24	220	260	751	887	1.53	1.58	5.22	5.39	CSR/RSCR	F/O	75	160	14	220	195	
C-BE200L2*	1/4	LBP	8.37	255	306	870	1,044	1.53	1.58	5.22	5.39	CSR/RSCR	F/O	75	160	14	220	195	
C-BE225L2*	1/3	LBP	9.03	275	330	939	1,127	1.55	1.60	5.29	5.46	CSR/RSCR	F/O	75	160	14	220	198	
C-BE250L2*	1/3	LBP	9.82	299	359	1,021	1,225	1.55	1.60	5.29	5.46	CSR/RSCR	F/O	75	160	14	220	198	
220-240V / 50Hz.																			
C-BE100L5*	1/8	LBP	4.50	113	**	386	**	1.40	**	4.78	**	CSR/RSCR	N	20	300	3.5-5	350	175	
C-BE110L5*	1/7	LBP	5.20	151	**	515	**	1.42	**	4.85	**	CSR/RSCR	N	20	300	3.5-5	350	175	
C-BE120L5*	1/6	LBP	5.70	162	**	553	**	1.41	**	4.81	**	CSR/RSCR	N	20	300	3.5-5	350	188	
C-BE140L5*	1/6	LBP	6.08	180	**	614	**	1.59	**	5.43	**	CSR/RSCR	N	20	300	3.5-5	350	188	
C-BE150L5*	1/5	LBP	6.65	195	**	665	**	1.59	**	5.43	**	CSR/RSCR	N	20	300	3.5-5	350	188	
C-BE175L5*	1/5	LBP	7.24	220	**	751	**	1.53	**	5.22	**	CSR/RSCR	F/O	20	300	3.5-5	350	195	
C-BE200L5*	1/4	LBP	8.37	255	**	870	**	1.53	**	5.22	**	CSR/RSCR	F/O	20	300	3.5-5	350	195	
C-BE225L5*	1/3	LBP	9.03	275	**	939	**	1.55	**	5.29	**	CSR/RSCR	F/O	20	300	3.5-5	350	198	
C-BE250L5*	1/3	LBP	9.82	299	**	1,021	**	1.55	**	5.29	**	CSR/RSCR	F/O	20	300	3.5-5	350	198	
200-220V / 50Hz., 220V / 60Hz.																			
C-BE100L6*	1/8	LBP	4.50	113	150	386	512	1.40	1.46	4.78	4.98	CSR/RSCR	N	20	300	3.5-5	350	175	
C-BE110L6*	1/7	LBP	5.20	151	180	515	614	1.42	1.53	4.85	5.22	CSR/RSCR	N	20	300	3.5-5	350	175	

Models	Power (HP)	App.	Disp. (cc)	Cooling (w)		Cooling (Btu)		COP (w/w)		EER (Btu/w)		Motor type	Cooling Type	Start Cap		Run Cap		Dim. "H1"
				50 Hz	60 Hz	50 Hz	60 Hz	50 Hz	60 Hz	50 Hz	60 Hz			50 Hz	60 Hz	mF	vac	
C-BE Series (High Performance)																		R134a
200-220V / 50Hz., 220V / 60Hz.																		
C-BE120L6*	1/6	LBP	5.70	162	196	553	669	1.41	1.55	4.81	5.29	CSR/RSCR	N	20	300	3.5-5	350	188
C-BE140L6*	1/6	LBP	6.08	180	214	614	730	1.59	1.64	5.43	5.60	CSR/RSCR	N	20	300	3.5-5	350	188
C-BE150L6*	1/5	LBP	6.65	195	235	665	802	1.59	1.64	5.43	5.60	CSR/RSCR	N	20	300	3.5-5	350	188
C-BE175L6*	1/5	LBP	7.24	220	260	751	887	1.53	1.58	5.22	5.39	CSR/RSCR	F/O	20	300	3.5-5	350	195
C-BE200L6*	1/4	LBP	8.37	255	306	870	1,044	1.53	1.58	5.22	5.39	CSR/RSCR	F/O	20	300	3.5-5	350	195
C-BE225L6*	1/3	LBP	9.03	275	330	939	1,127	1.55	1.60	5.29	5.46	CSR/RSCR	F/O	20	300	3.5-5	350	198
C-BE250L6*	1/3	LBP	9.82	299	359	1,021	1,225	1.55	1.60	5.29	5.46	CSR/RSCR	F/O	20	300	3.5-5	350	198

C-B Type

Models	Power (HP)	App.	Disp. (cc)	Cooling (w)		Cooling (Btu)		COP (w/w)		EER (Btu/w)		Motor type	Cooling type	Start Cap		Run Cap		Dim. "H1"
				50 Hz	60 Hz	50 Hz	60 Hz	50 Hz	60 Hz	50 Hz	60 Hz			50 Hz	60 Hz	mF	vac	
C-BF Series (Super High Performance)																		R134a
100V / 50Hz, 60Hz.																		
C-BF100L0*	1/8	LBP	4.50	132	154	452	526	1.57	1.62	5.36	5.53	RSCR	N	**	**	20	180	175
C-BF110L0*	1/7	LBP	5.20	153	178	522	607	1.59	1.64	5.43	5.60	RSCR	N	**	**	20	180	175
C-BF120L0*	1/6	LBP	5.70	165	194	563	662	1.57	1.62	5.36	5.53	RSCR	N	**	**	20	180	188
C-BF140L0*	1/6	LBP	6.08	182	212	621	723	1.69	1.74	5.77	5.94	RSCR	N	**	**	20	180	188
C-BF150L0*	1/5	LBP	6.68	197	233	672	795	1.68	1.72	5.73	5.87	RSCR	N	**	**	20	180	188
C-BF175L0*	1/5	LBP	7.24	222	258	758	880	1.65	1.73	5.63	5.90	RSCR	F/O	**	**	20	180	195
C-BF200L0*	1/4	LBP	8.37	255	306	870	1,044	1.70	1.73	5.80	5.90	RSCR	F/O	**	**	20	180	195
C-BF225L0*	1/3	LBP	9.03	275	330	939	1,127	1.70	1.73	5.80	5.90	RSCR	F/O	**	**	20	180	198
C-BF250L0*	1/3	LBP	9.82	299	359	1,021	1,225	1.70	1.73	5.80	5.90	RSCR	F/O	**	**	20	180	198
100V / 50Hz., 115-127V / 60Hz.																		
C-BF100L2*	1/8	LBP	4.50	132	154	452	526	1.57	1.62	5.36	5.53	RSCR	N	**	**	14	220	175
C-BF110L2*	1/7	LBP	5.20	153	178	522	607	1.59	1.64	5.43	5.60	RSCR	N	**	**	14	220	175
C-BF120L2*	1/6	LBP	5.70	165	194	563	662	1.57	1.62	5.36	5.53	RSCR	N	**	**	14	220	188
C-BF140L2*	1/6	LBP	6.08	182	212	621	723	1.69	1.74	5.77	5.94	RSCR	N	**	**	14	220	188
C-BF150L2*	1/5	LBP	6.65	197	233	672	795	1.68	1.72	5.73	5.87	RSCR	N	**	**	14	220	188
C-BF175L2*	1/5	LBP	7.24	222	258	758	880	1.65	1.73	5.63	5.90	RSCR	F/O	**	**	14	220	195
C-BF200L2*	1/4	LBP	8.37	255	306	870	1,044	1.70	1.73	5.80	5.90	RSCR	F/O	**	**	14	220	195
C-BF225L2*	1/3	LBP	9.03	275	330	939	1,127	1.70	1.73	5.80	5.90	RSCR	F/O	**	**	14	220	198
C-BF250L2*	1/3	LBP	9.82	299	359	1,021	1,225	1.70	1.73	5.80	5.90	RSCR	F/O	**	**	14	220	198
220-240V / 50Hz.																		
C-BF100L5*	1/8	LBP	4.50	132	**	452	**	1.57	**	5.36	**	RSCR	N	**	**	3.5-5	350	175
C-BF110L5*	1/7	LBP	5.20	153	**	522	**	1.59	**	5.43	**	RSCR	N	**	**	3.5-5	350	175
C-BF120L5*	1/6	LBP	5.70	165	**	563	**	1.57	**	5.36	**	RSCR	N	**	**	3.5-5	350	188
C-BF140L5*	1/6	LBP	6.08	182	**	621	**	1.69	**	5.77	**	RSCR	N	**	**	3.5-5	350	188
C-BF150L5*	1/5	LBP	6.65	197	**	672	**	1.68	**	5.73	**	RSCR	N	**	**	3.5-5	350	188
C-BF175L5*	1/5	LBP	7.24	222	**	758	**	1.65	**	5.63	**	RSCR	F/O	**	**	3.5-5	350	195
C-BF200L5*	1/4	LBP	8.37	255	**	870	**	1.70	**	5.80	**	RSCR	F/O	**	**	3.5-5	350	195
C-BF225L5*	1/3	LBP	9.03	275	**	939	**	1.70	**	5.80	**	RSCR	F/O	**	**	3.5-5	350	198
C-BF250L5*	1/3	LBP	9.82	299	**	1,021	**	1.70	**	5.80	**	RSCR	F/O	**	**	3.5-5	350	198
200-220V / 50Hz., 220V / 60Hz.																		
C-BF100L6*	1/8	LBP	4.50	132	154	452	526	1.57	1.62	5.36	5.53	RSCR	N	**	**	3.5-5	350	175
C-BF110L6*	1/7	LBP	5.20	153	178	522	607	1.59	1.64	5.43	5.60	RSCR	N	**	**	3.5-5	350	175
C-BF120L6*	1/6	LBP	5.70	165	194	563	662	1.57	1.62	5.36	5.53	RSCR	N	**	**	3.5-5	350	188
C-BF140L6*	1/6	LBP	6.08	182	212	621	723	1.69	1.74	5.77	5.94	RSCR	N	**	**	3.5-5	350	188
C-BF150L6*	1/5	LBP	6.65	197	233	672	795	1.68	1.72	5.73	5.87	RSCR	N	**	**	3.5-5	350	188
C-BF175L6*	1/5	LBP	7.24	222	258	758	880	1.65	1.73	5.63	5.90	RSCR	F/O	**	**	3.5-5	350	195
C-BF200L6*	1/4	LBP	8.37	255	306	870	1,044	1.70	1.73	5.80	5.90	RSCR	F/O	**	**	3.5-5	350	195
C-BF225L6*	1/3	LBP	9.03	275	330	939	1,127	1.70	1.73	5.80	5.90	RSCR	F/O	**	**	3.5-5	350	198
C-BF250L6*	1/3	LBP	9.82	299	359	1,021	1,225	1.70	1.73	5.80	5.90	RSCR	F/O	**	**	3.5-5	350	198

C-B Type

Models	Power (HP)	App.	Disp. (cc)	Cooling (w)				COP (w/w)				Motor type	Cooling Type	Start Cap		Run Cap		Dim. High
				Evap -6.7 °C		Evap 7.2 °C		Evap -6.7 °C		Evap 7.2 °C				mF	vac	mF	vac	
				50 Hz	60 Hz	50 Hz	60 Hz	50 Hz	60 Hz	50 Hz	60 Hz							
C-BZN Series (Standard Performance)																		R134a
100V / 50Hz, 60Hz.																		
C-BZN110MH0*	1/7	MHBP	4.16	226	268	447	523	1.71	1.75	2.50	2.54	CSIR/CSR	F/O	75	125	16	200	175
C-BZN120MH0*	1/6	MHBP	4.50	245	290	484	566	1.74	1.78	2.52	2.57	CSIR/CSR	F/O	75	125	16	200	175
C-BZN140MH0*	1/6	MHBP	5.20	283	335	559	654	1.74	1.78	2.52	2.57	CSIR/CSR	F/O	75	125	16	200	175
C-BZN170MH0*	1/5	MHBP	6.08	331	392	654	765	1.75	1.79	2.53	2.58	CSIR/CSR	F/O	75	125	16	200	188

Models	Power (HP)	App.	Disp. (cc)	Cooling (w)				COP (w/w)				Motor type	Cooling		Start Cap		Run Cap		Dim. High
				Evap -6.7 °C		Evap 7.2 °C		Evap -6.7 °C		Evap 7.2 °C			Type	mF	vac	mF	vac		
				50 Hz	60 Hz	50 Hz	60 Hz	50 Hz	60 Hz	50 Hz	60 Hz								

C-BZN Series (Standard Performance)																		R134a
100V / 50Hz, 60Hz.																		
C-BZN180MH0*	1/5	MHBP	6.65	361	428	715	837	1.75	1.79	2.53	2.58	CSIR/CSR	F/O	75	125	16	200	188
C-BZN200MH0*	1/4	MHBP	7.24	394	466	778	911	1.76	1.80	2.55	2.60	CSIR/CSR	F/O	75	125	16	200	188
C-BZN250MH0*	1/3	MHBP	8.37	455	539	900	1,053	1.76	1.80	2.55	2.60	CSIR/CSR	F/O	75	125	16	200	195
C-BZN275MH0*	1/3	MHBP	9.03	491	582	971	1,136	1.77	1.81	2.56	2.61	CSIR/CSR	F/O	75	125	16	200	198
C-BZN300MH0*	1/2	MHBP	9.82	534	632	1,056	1,235	1.77	1.81	2.56	2.61	CSIR/CSR	F/O	75	125	16	200	198
100V / 50Hz., 115-127V / 60Hz.																		
C-BZN110MH2*	1/7	MHBP	4.16	226	268	447	523	1.71	1.75	2.50	2.54	CSIR/CSR	F/O	75	125	15	220	175
C-BZN120MH2*	1/6	MHBP	4.50	245	290	484	566	1.74	1.78	2.52	2.57	CSIR/CSR	F/O	75	125	15	220	175
C-BZN140MH2*	1/6	MHBP	5.20	283	335	559	654	1.74	1.78	2.52	2.57	CSIR/CSR	F/O	75	125	15	220	175
C-BZN170MH2*	1/5	MHBP	6.08	331	392	654	765	1.75	1.79	2.53	2.58	CSIR/CSR	F/O	75	125	15	220	188
C-BZN180MH2*	1/5	MHBP	6.65	361	428	715	837	1.75	1.79	2.53	2.58	CSIR/CSR	F/O	75	125	15	220	188
C-BZN200MH2*	1/4	MHBP	7.24	394	466	778	911	1.76	1.80	2.55	2.60	CSIR/CSR	F/O	75	125	15	220	188
C-BZN250MH2*	1/3	MHBP	8.37	455	539	900	1,053	1.76	1.80	2.55	2.60	CSIR/CSR	F/O	75	125	15	220	195
C-BZN275MH2*	1/3	MHBP	9.03	491	582	971	1,136	1.77	1.81	2.56	2.61	CSIR/CSR	F/O	75	125	15	220	198
C-BZN300MH2*	1/2	MHBP	9.82	534	632	1,056	1,235	1.77	1.81	2.56	2.61	CSIR/CSR	F/O	75	125	15	220	198
200V / 50Hz, 60Hz.																		
C-BZN110MH3*	1/7	MHBP	4.16	226	268	447	523	1.71	1.75	2.50	2.54	CSIR/CSR	F/O	20	300	6	350	175
C-BZN120MH3*	1/6	MHBP	4.50	245	290	484	566	1.74	1.78	2.52	2.57	CSIR/CSR	F/O	20	300	6	350	175
C-BZN140MH3*	1/6	MHBP	5.20	283	335	559	654	1.74	1.78	2.52	2.57	CSIR/CSR	F/O	20	300	6	350	175
C-BZN170MH3*	1/5	MHBP	6.08	331	392	654	765	1.75	1.79	2.53	2.58	CSIR/CSR	F/O	20	300	6	350	188
C-BZN180MH3*	1/5	MHBP	6.65	361	428	715	837	1.75	1.79	2.53	2.58	CSIR/CSR	F/O	20	300	6	350	188
C-BZN200MH3*	1/4	MHBP	7.24	394	466	778	911	1.76	1.80	2.55	2.60	CSIR/CSR	F/O	20	300	6	350	188
C-BZN250MH3*	1/3	MHBP	8.37	455	539	900	1,053	1.76	1.80	2.55	2.60	CSIR/CSR	F/O	20	300	6	350	195
C-BZN275MH3*	1/3	MHBP	9.03	491	582	971	1,136	1.77	1.81	2.56	2.61	CSIR/CSR	F/O	20	300	6	350	198
C-BZN300MH3*	1/2	MHBP	9.82	534	632	1,056	1,235	1.77	1.81	2.56	2.61	CSIR/CSR	F/O	20	300	6	350	198
220-240V / 50Hz.																		
C-BZN110MH5*	1/7	MHBP	4.16	226	**	447	**	1.71	**	2.50	**	CSIR/CSR	F/O	20	300	3.5-5	350	175
C-BZN120MH5*	1/6	MHBP	4.50	245	**	484	**	1.74	**	2.52	**	CSIR/CSR	F/O	20	300	3.5-5	350	175
C-BZN140MH5*	1/6	MHBP	5.20	283	**	559	**	1.74	**	2.52	**	CSIR/CSR	F/O	20	300	3.5-5	350	175
C-BZN170MH5*	1/5	MHBP	6.08	331	**	654	**	1.75	**	2.53	**	CSIR/CSR	F/O	20	300	3.5-5	350	188
C-BZN180MH5*	1/5	MHBP	6.65	361	**	715	**	1.75	**	2.53	**	CSIR/CSR	F/O	20	300	3.5-5	350	188
C-BZN200MH5*	1/4	MHBP	7.24	394	**	778	**	1.76	**	2.55	**	CSIR/CSR	F/O	20	300	3.5-5	350	188
C-BZN250MH5*	1/3	MHBP	8.37	455	**	900	**	1.76	**	2.55	**	CSIR/CSR	F/O	20	300	3.5-5	350	195
C-BZN275MH5*	1/3	MHBP	9.03	491	**	971	**	1.77	**	2.56	**	CSIR/CSR	F/O	20	300	3.5-5	350	198
C-BZN300MH5*	1/2	MHBP	9.82	534	**	1,056	**	1.77	**	2.56	**	CSIR/CSR	F/O	20	300	3.5-5	350	198
200-220V / 50Hz., 220V / 60Hz.																		
C-BZN110MH6*	1/7	MHBP	4.16	226	268	447	523	1.71	1.75	2.50	2.54	CSIR/CSR	F/O	20	300	3.5-5	350	175
C-BZN120MH6*	1/6	MHBP	4.50	245	290	484	566	1.74	1.78	2.52	2.57	CSIR/CSR	F/O	20	300	3.5-5	350	175
C-BZN140MH6*	1/6	MHBP	5.20	283	335	559	654	1.74	1.78	2.52	2.57	CSIR/CSR	F/O	20	300	3.5-5	350	175
C-BZN170MH6*	1/5	MHBP	6.08	331	392	654	765	1.75	1.79	2.53	2.58	CSIR/CSR	F/O	20	300	3.5-5	350	188
C-BZN180MH6*	1/5	MHBP	6.65	361	428	715	837	1.75	1.79	2.53	2.58	CSIR/CSR	F/O	20	300	3.5-5	350	188
C-BZN200MH6*	1/4	MHBP	7.24	394	466	778	911	1.76	1.80	2.55	2.60	CSIR/CSR	F/O	20	300	3.5-5	350	188
C-BZN250MH6*	1/3	MHBP	8.37	455	539	900	1,053	1.76	1.80	2.55	2.60	CSIR/CSR	F/O	20	300	3.5-5	350	195
C-BZN275MH6*	1/3	MHBP	9.03	491	582	971	1,136	1.77	1.81	2.56	2.61	CSIR/CSR	F/O	20	300	3.5-5	350	198
C-BZN300MH6*	1/2	MHBP	9.82	534	632	1,056	1,235	1.77	1.81	2.56	2.61	CSIR/CSR	F/O	20	300	3.5-5	350	198

C-B Type

Models	Power (HP)	App.	Disp. (cc)	Cooling (w)		Cooling (Btu)		COP (w/w)		EER (Btu/w)		Motor type	Cooling		Start Cap		Run Cap		Dim. High
				50 Hz	60 Hz	50 Hz	60 Hz	50 Hz	60 Hz	50 Hz	60 Hz		Type	mF	vac	mF	vac		
				50 Hz	60 Hz	50 Hz	60 Hz	50 Hz	60 Hz										

C-BH Series (High Performance)																		R600a
100V / 50Hz, 60Hz.																		
C-BH90L0*	1/8	LBP	6.08	95	114	324	389	1.57	1.58	5.36	5.39	RSCR	N/F	**	**	10	180	178
C-BH100L0*	1/8	LBP	7.24	116	136	396	464	1.60	1.66	5.46	5.67	RSCR	N/F	**	**	10	180	188
C-BH110L0*	1/7	LBP	7.87	131	156	447	532	1.62	1.66	5.53	5.67	RSCR	N/F	**	**	10	180	188
C-BH130L0*	1/6	LBP	9.03	160	182	546	621	1.66	1.70	5.67	5.80	RSCR	N/F	**	**	10	180	200
C-BH140L0*	1/6	LBP	9.82	172	197	587	672	1.68	1.71	5.73	5.84	RSCR	N/F	**	**	10	180	200
100V / 50Hz., 115-127V / 60Hz.																		
C-BH90L2*	1/8	LBP	6.08	**	114	**	389	**	1.58	**	5.39	RSCR	N/F	**	**	10	200	178
C-BH100L2*	1/8	LBP	7.24	**	137	**	468	**	1.66	**	5.67	RSCR	N/F	**	**	10	200	188
C-BH110L2*	1/7	LBP	7.87	**	156	**	532	**	1.66	**	5.67	RSCR	N/F	**	**	10	200	188
C-BH130L2*	1/6	LBP	9.03	**	182	**	621	**	1.70	**	5.80	RSCR	N/F	**	**	10	200	200
C-BH140L2*	1/6	LBP	9.82	**	197	**	672	**	1.71	**	5.84	RSCR	N/F	**	**	10	200	200
220-240V / 50Hz.																		

Models	Power (HP)	App.	Disp. (cc)	Cooling (w)		Cooling (Btu)		COP (w/w)		EER (Btu/w)		Motor type	Cooling Type	Start Cap		Run Cap		Dim. High
				50 Hz	60 Hz	50 Hz	60 Hz	50 Hz	60 Hz	50 Hz	60 Hz			mF	vac	mF	vac	
C-BH Series (High Performance)																		R600a
220-240V / 50Hz.																		
C-BH90L5*	1/8	LBP	6.08	95	**	324	**	1.57	**	5.36	**	RSCR	N/F	**	**	3-5	350	178
C-BH100L5*	1/8	LBP	7.24	116	**	396	**	1.60	**	5.46	**	RSCR	N/F	**	**	3-5	350	188
C-BH110L5*	1/7	LBP	7.87	131	**	447	**	1.62	**	5.53	**	RSCR	N/F	**	**	3-5	350	188
C-BH130L5*	1/6	LBP	9.03	160	**	546	**	1.66	**	5.67	**	RSCR	N/F	**	**	3-5	350	200
C-BH140L5*	1/6	LBP	9.82	172	**	587	**	1.68	**	5.73	**	RSCR	N/F	**	**	3-5	350	200
200-220V / 50Hz., 220V / 60Hz.																		
C-BH90L6*	1/8	LBP	6.08	95	114	324	389	1.57	1.58	5.36	5.39	RSCR	N/F	**	**	3-5	350	178
C-BH100L6*	1/8	LBP	7.24	116	137	396	468	1.60	1.66	5.46	5.67	RSCR	N/F	**	**	3-5	350	188
C-BH110L6*	1/7	LBP	7.87	131	156	447	532	1.62	1.66	5.53	5.67	RSCR	N/F	**	**	3-5	350	188
C-BH130L6*	1/6	LBP	9.03	160	182	546	621	1.66	1.70	5.67	5.80	RSCR	N/F	**	**	3-5	350	200
C-BH140L6*	1/6	LBP	9.82	172	197	587	672	1.68	1.71	5.73	5.84	RSCR	N/F	**	**	3-5	350	200

C-B Type

Models	Power (HP)	App.	Disp. (cc)	Cooling (w)		Cooling (Btu)		COP (w/w)		EER (Btu/w)		Motor type	Cooling Type	Start Cap		Run Cap		Dim. High
				50 Hz	60 Hz	50 Hz	60 Hz	50 Hz	60 Hz	50 Hz	60 Hz			50 Hz	60 Hz	mF	vac	
C-BR Series																		R404A
100V / 50Hz, 60Hz.																		
C-BR225L0*	1/3	LBP	5.20	263	293	898	1,000	1.21	1.24	4.13	4.23	CSR	F/O	125	160	25	220	188
C-BR250L0*	1/3	LBP	5.70	303	343	1,034	1,171	1.26	1.28	4.30	4.37	CSR	F/O	125	160	25	220	195
C-BR300L0*	1/2	LBP	6.08	333	394	1,136	1,345	1.34	1.36	4.57	4.64	CSR	F/O	125	160	25	220	195
C-BR350L0*	1/2	LBP	6.79	384	449	1,310	1,532	1.34	1.36	4.57	4.64	CSR	F/O	125	160	25	220	195
C-BR400L0*	1/2	LBP	7.24	409	470	1,396	1,604	1.38	1.41	4.71	4.81	CSR	F/O	125	160	25	220	195
C-BR425L0*	1/2	LBP	8.37	480	555	1,638	1,894	1.45	1.48	4.95	5.05	CSR	F/O	125	160	25	220	195
C-BR450L0*	1/2	LBP	9.03	518	601	1,767	2,050	1.45	1.48	4.95	5.05	CSR	F/O	125	160	25	220	198
C-BR475L0*	1/2	LBP	9.82	563	653	1,922	2,229	1.45	1.48	4.95	5.05	CSR	F/O	125	160	25	220	198
100V / 50Hz., 115-127V / 60Hz.																		
C-BR225L2*	1/3	LBP	5.20	262	293	894	1,000	1.21	1.24	4.13	4.23	CSR	F/O	100	160	20	220	188
C-BR250L2*	1/3	LBP	5.70	303	343	1,034	1,171	1.26	1.28	4.30	4.37	CSR	F/O	100	160	20	220	195
C-BR300L2*	1/2	LBP	6.08	333	394	1,136	1,345	1.34	1.36	4.57	4.64	CSR	F/O	100	160	20	220	195
C-BR350L2*	1/2	LBP	6.79	384	449	1,310	1,532	1.34	1.36	4.57	4.64	CSR	F/O	100	160	20	220	195
C-BR400L2*	1/2	LBP	7.24	410	470	1,399	1,604	1.38	1.41	4.71	4.81	CSR	F/O	100	160	20	220	195
C-BR425L2*	1/2	LBP	8.37	479	556	1,635	1,897	1.45	1.48	4.95	5.05	CSR	F/O	100	160	20	220	195
C-BR450L2*	1/2	LBP	9.03	518	601	1,767	2,050	1.45	1.48	4.95	5.05	CSR	F/O	100	160	20	220	198
C-BR475L2*	1/2	LBP	9.82	563	653	1,922	2,229	1.45	1.48	4.95	5.05	CSR	F/O	100	160	20	220	198
220-240V / 50Hz.																		
C-BR225L5*	1/3	LBP	5.20	262	**	894	**	1.21	**	4.13	**	CSR	F/O	40	300	6	400	188
C-BR250L5*	1/3	LBP	5.70	303	**	1,034	**	1.26	**	4.30	**	CSR	F/O	40	300	6	400	195
C-BR300L5*	1/2	LBP	6.08	333	**	1,136	**	1.34	**	4.57	**	CSR	F/O	40	300	6	400	195
C-BR350L5*	1/2	LBP	6.79	384	**	1,310	**	1.34	**	4.57	**	CSR	F/O	40	300	6	400	195
C-BR400L5*	1/2	LBP	7.24	409	**	1,396	**	1.38	**	4.71	**	CSR	F/O	40	300	6	400	195
C-BR425L5*	1/2	LBP	8.37	480	**	1,638	**	1.45	**	4.95	**	CSR	F/O	40	300	6	400	195
C-BR450L5*	1/2	LBP	9.03	518	**	1,767	**	1.45	**	4.95	**	CSR	F/O	40	300	6	400	198
C-BR475L5*	1/2	LBP	9.82	563	**	1,922	**	1.45	**	4.95	**	CSR	F/O	40	300	6	400	198
200-220V / 50Hz., 220V / 60Hz.																		
C-BR225L6*	1/3	LBP	5.20	262	293	894	1,000	1.21	1.24	4.13	4.23	CSR	F/O	40	300	6	400	188
C-BR250L6*	1/3	LBP	5.70	303	343	1,034	1,171	1.26	1.28	4.30	4.37	CSR	F/O	40	300	6	400	195
C-BR300L6*	1/2	LBP	6.08	333	394	1,136	1,345	1.34	1.36	4.57	4.64	CSR	F/O	40	300	6	400	195
C-BR350L6*	1/2	LBP	6.79	384	449	1,310	1,532	1.34	1.36	4.57	4.64	CSR	F/O	40	300	6	400	195
C-BR400L6*	1/2	LBP	7.24	409	470	1,396	1,604	1.37	1.41	4.68	4.81	CSR	F/O	40	300	6	400	195
C-BR425L6*	1/2	LBP	8.37	479	555	1,635	1,894	1.44	1.48	4.91	5.05	CSR	F/O	40	300	6	400	195
C-BR450L6*	1/2	LBP	9.03	518	601	1,767	2,050	1.45	1.48	4.95	5.05	CSR	F/O	40	300	6	400	198
C-BR475L6*	1/2	LBP	9.82	563	653	1,922	2,229	1.45	1.48	4.95	5.05	CSR	F/O	40	300	6	400	198

C-B Type

Models	Power (HP)	App.	Disp. (cc)	Cooling (w)				COP (w/w)				Motor type	Cooling Type	Start Cap		Run Cap		Comp High (mm)
				Evap -23.3 °C		Evap -6.7 °C		Evap -23.3 °C		Evap -6.7 °C				mF	vac	mF	vac	
				50 Hz	60 Hz	50 Hz	60 Hz	50 Hz	60 Hz	50 Hz	60 Hz							
C-BHR Series																		R290
100V / 50Hz, 60Hz.																		
C-BHR100LM0*	1/8	LMBP	2.55	92	115	190	238	1.15	1.20	1.75	1.80	CSR	F/O	100	160	30	220	177
C-BHR125LM0*	1/6	LMBP	2.98	112	140	232	290	1.28	1.25	1.80	1.85	CSR	F/O	100	160	30	220	177

Models	Power (HP)	App.	Disp. (cc)	Cooling (w)				COP (w/w)				Motor type	Cooling Type	Start Cap		Run Cap		Comp High (mm)	
				Evap -23.3 °C		Evap -6.7 °C		Evap -23.3 °C		Evap -6.7 °C				mF	vac	mF	vac		
				50 Hz	60 Hz	50 Hz	60 Hz	50 Hz	60 Hz	50 Hz	60 Hz								
C-BHR Series																			R290
100V / 50Hz, 60Hz.																			
C-BHR150LM0*	1/5	LMBP	3.68	160	200	298	372	1.35	1.40	1.90	2.00	CSR	F/O	100	160	30	220	177	
C-BHR175LM0*	1/5	LMBP	4.16	181	226	332	415	1.40	1.45	1.90	2.00	CSR	F/O	100	160	30	220	188	
C-BHR200LM0*	1/4	LMBP	5.20	226	282	436	545	1.40	1.45	1.90	2.00	CSR	F/O	100	160	30	220	188	
C-BHR225LM0*	1/3	LMBP	5.70	260	325	476	595	1.40	1.45	1.90	2.00	CSR	F/O	100	160	30	220	188	
C-BHR250LM0*	1/3	LMBP	6.08	278	347	508	635	1.40	1.45	1.90	2.00	CSR	F/O	100	160	30	220	188	
C-BHR325LM0*	1/2	LMBP	6.79	296	370	564	705	1.40	1.45	1.90	2.00	CSR	F/O	100	160	30	220	195	
C-BHR350LM0*	1/2	LMBP	7.24	328	410	592	740	1.45	1.50	1.90	2.00	CSR	F/O	100	160	30	220	195	
C-BHR400LM0*	1/2	LMBP	8.37	392	490	716	895	1.45	1.50	1.90	2.00	CSR	F/O	100	160	30	220	195	
C-BHR425LM0*	1/2	LMBP	9.03	424	530	740	925	1.45	1.50	1.80	1.85	CSR	F/O	100	160	40	220	198	
C-BHR450LM0*	1/2	LMBP	9.82	452	565	824	1,030	1.45	1.50	1.80	1.85	CSR	F/O	100	160	40	220	198	
100V/50Hz, 115-127V / 60Hz.																			
C-BHR100LM2*	1/8	LMBP	2.55	92	115	190	238	1.20	1.30	1.80	1.95	CSR	F/O	100	160	10	220	177	
C-BHR125LM2*	1/6	LMBP	2.98	112	140	232	290	1.25	1.32	1.85	2.00	CSR	F/O	100	160	10	220	177	
C-BHR150LM2*	1/5	LMBP	3.68	160	200	298	372	1.40	1.53	2.00	2.10	CSR	F/O	100	160	10	220	177	
C-BHR175LM2*	1/5	LMBP	4.16	181	226	332	415	1.45	1.60	2.00	2.10	CSR	F/O	100	160	16	220	188	
C-BHR200LM2*	1/4	LMBP	5.20	226	282	436	545	1.45	1.53	2.00	2.10	CSR	F/O	100	160	20	220	188	
C-BHR225LM2*	1/3	LMBP	5.70	260	325	476	595	1.45	1.57	2.00	2.10	CSR	F/O	125	160	20	220	188	
C-BHR250LM2*	1/3	LMBP	6.08	278	347	508	635	1.45	1.55	2.00	2.10	CSR	F/O	125	160	20	220	188	
C-BHR325LM2*	1/2	LMBP	6.79	296	370	564	705	1.45	1.55	2.00	2.10	CSR	F/O	125	160	25	220	195	
C-BHR350LM2*	1/2	LMBP	7.24	328	410	592	740	1.50	1.60	2.00	2.10	CSR	F/O	125	160	25	220	195	
C-BHR400LM2*	1/2	LMBP	8.37	392	490	716	895	1.50	1.60	2.00	2.10	CSR	F/O	125	160	30	220	195	
C-BHR425LM2*	1/2	LMBP	9.03	424	530	740	925	1.50	1.60	1.85	2.00	CSR	F/O	125	160	30	220	198	
C-BHR450LM2*	1/2	LMBP	9.82	452	565	824	1,030	1.50	1.60	1.85	2.00	CSR	F/O	125	160	30	220	198	
220-240V / 50Hz.																			
C-BHR100LM5*	1/8	LMBP	2.55	92	**	190	**	1.20	**	1.80	**	CSR	F/O	25	300	4-5	400	177	
C-BHR125LM5*	1/6	LMBP	2.98	112	**	232	**	1.25	**	1.85	**	CSR	F/O	25	300	4-5	400	177	
C-BHR150LM5*	1/5	LMBP	3.68	160	**	298	**	1.40	**	2.00	**	CSR	F/O	25	300	4-5	400	177	
C-BHR175LM5*	1/5	LMBP	4.16	181	**	332	**	1.45	**	2.00	**	CSR	F/O	25	300	4-5	400	188	
C-BHR200LM5*	1/4	LMBP	5.20	226	**	436	**	1.45	**	2.00	**	CSR	F/O	25	300	4-5	400	188	
C-BHR225LM5*	1/3	LMBP	5.70	260	**	476	**	1.45	**	2.00	**	CSR	F/O	25	300	4-5	400	188	
C-BHR250LM5*	1/3	LMBP	6.08	278	**	508	**	1.45	**	2.00	**	CSR	F/O	25	300	4-5	400	188	
C-BHR325LM5*	1/2	LMBP	6.79	296	**	564	**	1.45	**	2.00	**	CSR	F/O	25	300	4-5	400	195	
C-BHR350LM5*	1/2	LMBP	7.24	328	**	592	**	1.50	**	2.00	**	CSR	F/O	25	300	4-5	400	195	
C-BHR400LM5*	1/2	LMBP	8.37	392	**	716	**	1.50	**	2.00	**	CSR	F/O	25	300	4-5	400	195	
C-BHR425LM5*	1/2	LMBP	9.03	424	**	740	**	1.50	**	1.85	**	CSR	F/O	25	300	4-5	400	198	
C-BHR450LM5*	1/2	LMBP	9.82	452	**	824	**	1.50	**	1.85	**	CSR	F/O	25	300	4-5	400	198	
200-220V / 50Hz., 220V / 60Hz.																			
C-BHR100LM6*	1/8	LMBP	2.55	92	115	190	238	1.20	1.30	1.80	1.95	CSR	F/O	25	300	4-5	400	177	
C-BHR125LM6*	1/6	LMBP	2.98	112	140	232	290	1.25	1.32	1.85	2.00	CSR	F/O	25	300	4-5	400	177	
C-BHR150LM6*	1/5	LMBP	3.68	160	200	298	372	1.40	1.53	2.00	2.10	CSR	F/O	25	300	4-5	400	177	
C-BHR175LM6*	1/5	LMBP	4.16	181	226	332	415	1.45	1.60	2.00	2.10	CSR	F/O	25	300	4-5	400	188	
C-BHR200LM6*	1/4	LMBP	5.20	226	282	436	545	1.45	1.53	2.00	2.10	CSR	F/O	25	300	4-5	400	188	
C-BHR225LM6*	1/3	LMBP	5.70	260	325	476	595	1.45	1.57	2.00	2.10	CSR	F/O	25	300	4-5	400	188	
C-BHR250LM6*	1/3	LMBP	6.08	278	347	508	635	1.45	1.55	2.00	2.10	CSR	F/O	25	300	4-5	400	188	
C-BHR325LM6*	1/2	LMBP	6.79	296	370	564	705	1.45	1.55	2.00	2.10	CSR	F/O	25	300	4-5	400	195	
C-BHR350LM6*	1/2	LMBP	7.24	328	410	592	740	1.50	1.60	2.00	2.10	CSR	F/O	25	300	4-5	400	195	
C-BHR400LM6*	1/2	LMBP	8.37	392	490	716	895	1.50	1.60	2.00	2.10	CSR	F/O	25	300	4-5	400	195	
C-BHR425LM6*	1/2	LMBP	9.03	424	530	740	925	1.50	1.60	1.85	2.00	CSR	F/O	25	300	4-5	400	195	
C-BHR450LM6*	1/2	LMBP	9.82	452	565	824	1,030	1.50	1.60	1.85	2.00	CSR	F/O	25	300	4-5	400	195	

C3B (3 Phase) Type

Models	App.	Motor type	Disp. (cc)	Cooling (w)		Cooling (Btu)		COP (w/w)		EER (Btu/w)		Dim. High
				50 Hz	60 Hz	50 Hz	60 Hz	50 Hz	60 Hz	50 Hz	60 Hz	
C3BR Series (Standard Performance)												R404A
200V / 50Hz, 60Hz.												
C3BR225L3*	LBP	3IR	5.20	260	290	887	990	1.20	1.23	4.10	4.20	188
C3BR250L3*	LBP	3IR	5.70	300	340	1,024	1,160	1.25	1.27	4.27	4.33	188
C3BR300L3*	LBP	3IR	6.08	322	386	1,099	1,317	1.35	1.37	4.61	4.68	195
C3BR350L3*	LBP	3IR	6.79	380	445	1,297	1,519	1.36	1.39	4.64	4.74	195

Models	App.	Motor type	Disp. (cc)	Cooling (w)		Cooling (Btu)		COP (w/w)		EER (Btu/w)		Dim. High
				50 Hz	60 Hz	50 Hz	60 Hz	50 Hz	60 Hz	50 Hz	60 Hz	

C3BR Series (Standard Performance)

R 404A

200V / 50Hz, 60Hz.

C3BR400L3*	LBP	3IR	7.24	405	465	1,382	1,587	1.37	1.40	4.68	4.78	195
C3BR425L3*	LBP	3IR	8.37	452	520	1,543	1,775	1.40	1.44	4.78	4.91	195

C3BHR Series (Standard Performance)

R 290

200V / 50Hz, 60Hz.

C3BHR200L3*	LBP	3IR	5.20	250	295	843	993	1.38	1.46	4.71	4.98	188
C3BHR225L3*	LBP	3IR	5.70	275	320	921	1,085	1.38	1.44	4.71	4.91	188
C3BHR250L3*	LBP	3IR	6.08	290	340	983	1,160	1.43	1.51	4.88	5.15	188
C3BHR325L3*	LBP	3IR	6.79	325	380	1,099	1,297	1.41	1.50	4.81	5.12	195
C3BHR350L3*	LBP	3IR	7.24	345	405	1,171	1,596	1.45	1.53	4.95	5.22	195
C3BHR400L3*	LBP	3IR	8.37	400	470	1,354		1.47	1.56	5.02	5.32	195

C3BE Series (Standard Performance)

R 134a

200V / 50Hz, 60Hz.

C3BE110L3*	LBP	3IR	5.20	149	178	508	607	1.31	1.35	4.47	4.61	178
C3BE110L3*	LBP	3IR	5.20	149	178	508	607	1.41	1.47	4.81	5.02	178
C3BE140L3*	LBP	3IR	6.08	178	212	607	723	1.45	1.50	4.95	5.12	188
C3BE150L3*	LBP	3IR	6.65	193	233	659	795	1.48	1.54	5.05	5.26	195
C3BE175L3*	LBP	3IR	7.24	218	258	744	880	1.49	1.55	5.08	5.29	195
C3BE200L3*	LBP	3IR	8.37	255	300	870	1,024	1.52	1.57	5.19	5.36	195

CKVH Series BLDC Compressor

R600a

Models	App	Displ.	COMPRESSOR RUNING SPEED (RPM)	ASHRAE 32 CONDITION									COOLING Type	High (mm)
				Speed	COOLING CAPACITY			INPUT	EFFICIENCY					
					RPM	Kcal/hr	Watt		Btu/hr	Watt	EER Kcal/Whr	COP W/W		
CKVH90L*	LBP	6.08	1380-4020	2000	62	73	248	45	1.39	1.61	5.50	N/F	175	
				2500	78	91	311	55	1.43	1.66	5.65			
				3000	87	101	345	65	1.34	1.56	5.31			
				3500	108	125	427	75	1.44	1.67	5.69			
CKVH110L*	LBP	7.87	1380-4020	2000	81	94	321	56	1.44	1.68	5.72	N/F	175	
				2500	101	118	402	69	1.47	1.71	5.83			
				3000	113	131	447	80	1.41	1.64	5.58			
				3500	139	162	552	96	1.45	1.69	5.75			
CKVH130L*	LBP	9.08	1380-4020	2000	93	108	368	65	1.43	1.66	5.67	N/F	175	
				2500	116	135	460	79	1.47	1.71	5.83			
				3000	140	163	556	96	1.46	1.70	5.79			
				3500	159	185	631	113	1.41	1.64	5.58			
CKVH140L*	LBP	9.82	1380-4020	2000	108	125	426	69	1.56	1.81	6.18	N/F	175	
				2500	137	159	542	86	1.59	1.85	6.30			
				3000	159	185	631	104	1.53	1.78	6.07			
				3500	179	208	709	122	1.47	1.70	5.81			

CKVE Series BLDC Compressor

R134a

Models	App	Displ.	COMPRESSOR RUNING SPEED (RPM)	ASHRAE 32 CONDITION									COOLING Type	High (mm)
				Speed	COOLING CAPACITY			INPUT	EFFICIENCY					
					RPM	Kcal/hr	Watt		Btu/hr	Watt	EER Kcal/Whr	COP W/W		
CKVE90L*	LBP	4.16	1380-4020	2000	65.36	76	259	48	1.36	1.58	5.40	N/F	175	
				2500	81.7	95	324	58	1.41	1.64	5.59			
				3000	98.9	115	392	71	1.39	1.62	5.52			
				3500	116.1	135	460	84	1.38	1.61	5.48			
CKVE110L*	LBP	5.2	1380-4020	2000	88	102	348	65	1.35	1.57	5.35	N/F	175	
				2500	114	133	454	83	1.38	1.60	5.46			
				3000	138	160	546	100	1.38	1.60	5.46			
				3500	160	186	634	119	1.34	1.56	5.33			
CKVE140L*	LBP	6.08	1380-4020	2000	99	115	392	71	1.39	1.62	5.52	N/F	175	
				2500	125	145	494	90	1.39	1.61	5.49			
				3000	155	180	614	112	1.38	1.61	5.48			
				3500	181	210	716	135	1.34	1.56	5.30			
CKVE150L*	LBP	6.65	1380-4020	2000	108	126	429	78	1.39	1.61	5.50	N/F	175	
				2500	136	159	541	98	1.39	1.62	5.52			
				3000	169	197	671	120	1.41	1.64	5.59			
				3500	198	230	783	143	1.38	1.61	5.48			

CKVE Series BLDC Compressor													R134a	
Models	App	Displ.	COMPRESSOR RUNING SPEED (RPM)	ASHRAE 32 CONDITION									COOLING Type	High (mm)
				Speed	COOLING CAPACITY			INPUT	EFFICIENCY					
					RPM	Kcal/hr	Watt		Btu/hr	Watt	EER Kcal/W/hr	COP W/W		
CKVE175L*	LBP	7.24	1380-4020	2000	114	132	451	83	1.37	1.59	5.43	N/F	175	
				2500	159	185	631	114	1.40	1.62	5.53			
				3000	191	222	757	138	1.38	1.61	5.49			
				3500	220	256	873	164	1.34	1.56	5.32			
CKVE200L*	LBP	8.37	1380-4020	2000	144	167	569	110	1.31	1.52	5.18	N/F	175	
				2500	181	211	720	130	1.40	1.62	5.53			
				3000	220	256	873	160	1.38	1.60	5.46			
				3500	255	297	1013	192	1.33	1.55	5.27			
CKVE225L*	LBP	9.08	1380-4020	2000	156	181	618	115	1.35	1.58	5.37	N/F	175	
				2500	197	229	781	140	1.41	1.63	5.58			
				3000	239	278	947	170	1.40	1.63	5.57			
				3500	277	322	1099	200	1.39	1.61	5.49			
CKVE252L*	LBP	9.82	1380-4020	2000	169	196	668	120	1.40	1.63	5.57	Fan	188	
				2500	213	248	844	145	1.47	1.71	5.82			
				3000	258	300	1024	175	1.48	1.72	5.85			
				3500	300	348	1188	205	1.46	1.70	5.80			

CKVE Series BLDC Compressor													R134a	
Models	App	Displ.	COMPRESSOR RUNING SPEED (RPM)	ASHRAE 32 CONDITION									COOLING Type	High (mm)
				Speed	COOLING CAPACITY			INPUT	EFFICIENCY					
					RPM	Kcal/hr	Watt		Btu/hr	Watt	EER Kcal/W/hr	COP W/W		
CKVE110M*	MBP	4.16	1380-4020	2000	137	160	544	78	1.76	2.05	6.98	Fan	175	
				2500	172	200	680	98	1.75	2.04	6.94			
				3000	208	242	824	120	1.73	2.01	6.86			
				3500	244	284	967	140	1.74	2.03	6.91			
CKVE140M*	MBP	5.2	1380-4020	2000	184	214	730	105	1.75	2.04	6.96	Fan	175	
				2500	240	279	952	135	1.78	2.07	7.05			
				3000	289	336	1146	160	1.81	2.10	7.16			
				3500	336	391	1332	187	1.80	2.09	7.12			
CKVE175M*	MBP	6.08	1380-4020	2000	208	242	824	115	1.81	2.10	7.16	Fan	175	
				2500	262	305	1038	145	1.81	2.10	7.16			
				3000	325	378	1289	180	1.81	2.10	7.16			
				3500	379	441	1504	214	1.77	2.06	7.03			
CKVE182M*	MBP	6.65	1380-4020	2000	227	264	901	130	1.75	2.03	6.93	Fan	188	
				2500	286	333	1136	160	1.79	2.08	7.10			
				3000	356	413	1410	195	1.82	2.12	7.23			
				3500	415	482	1645	230	1.80	2.10	7.15			
CKVE202M*	MBP	7.24	1380-4020	2000	239	278	947	135	1.77	2.06	7.02	Fan	188	
				2500	334	389	1325	190	1.76	2.04	6.97			
				3000	401	466	1590	220	1.82	2.12	7.23			
				3500	462	538	1833	260	1.78	2.07	7.05			
CKVE222M*	MBP	8.37	1380-4020	2000	302	351	1196	165	1.83	2.13	7.25	Fan	188	
				2500	381	443	1511	209	1.82	2.12	7.23			
				3000	462	538	1833	259	1.79	2.08	7.08			
				3500	536	624	2127	304	1.76	2.05	7.00			
CKVE252M*	MBP	9.08	1380-4020	2000	327	380	1297	180	1.82	2.11	7.21	Fan	188	
				2500	413	481	1639	225	1.84	2.14	7.29			
				3000	502	583	1989	278	1.80	2.10	7.15			
				3500	582	677	2307	330	1.76	2.05	6.99			
CKVE272M*	MBP	9.82	1380-4020	2000	354	411	1403	195	1.81	2.11	7.20	Fan	188	
				2500	447	520	1773	245	1.82	2.12	7.24			
				3000	542	631	2151	295	1.84	2.14	7.29			
				3500	629	732	2495	350	1.80	2.09	7.13			

CKVR Series BLDC Compressor													R404A	
Models	App	Displ.	COMPRESSOR RUNING SPEED (RPM)	ASHRAE 32 CONDITION									COOLING Type	High (mm)
				Speed	COOLING CAPACITY			INPUT	EFFICIENCY					
					RPM	Kcal/hr	Watt		Btu/hr	Watt	EER Kcal/W/hr	COP W/W		
CKVR225L*	LBP	5.2	1380-4020	2000	172	200	682	127	1.35	1.57	5.37	Fan	175	
				2500	224	260	887	156	1.43	1.67	5.68			
				3000	272	316	1078	196	1.39	1.61	5.50			
				3500	312	363	1238	227	1.38	1.60	5.45			
CKVR252L*	LBP	5.7	1380-4020	2000	189	219	748	134	1.41	1.64	5.58	Fan	188	
				2500	245	285	972	168	1.46	1.70	5.78			
				3000	298	346	1181	208	1.43	1.67	5.68			
				3500	342	398	1357	240	1.43	1.66	5.65			
CKVR302L*	LBP	6.08	1380-4020	2000	201	234	797	143	1.41	1.64	5.58	Fan	188	
				2500	261	304	1037	179	1.46	1.70	5.79			
				3000	318	369	1260	218	1.46	1.69	5.78			
				3500	365	424	1447	254	1.44	1.67	5.70			
CKVR352L*	LBP	6.79	1380-4020	2000	225	261	891	160	1.40	1.63	5.57	Fan	188	
				2500	292	340	1158	200	1.46	1.70	5.79			
				3000	355	413	1407	242	1.47	1.71	5.81			
				3500	408	474	1616	280	1.46	1.69	5.77			
CKVR402L*	LBP	7.24	1380-4020	2000	239	278	950	173	1.38	1.61	5.49	Fan	188	
				2500	311	362	1234	215	1.45	1.68	5.74			
				3000	378	440	1500	260	1.46	1.69	5.77			
				3500	435	505	1723	300	1.45	1.68	5.74			
CKVR422L*	LBP	8.37	1380-4020	2000	277	322	1098	197	1.41	1.63	5.57	Fan	188	
				2500	360	419	1427	250	1.44	1.67	5.71			
				3000	437	509	1734	308	1.42	1.65	5.63			
				3500	502	584	1992	358	1.40	1.63	5.57			

CKVR Series BLDC Compressor											R404A			
Models	App	Displ.	COMPRESSOR RUNING SPEED (RPM)	ASHRAE 32 CONDITION									COOLING Type	High (mm)
				Speed	COOLING CAPACITY			INPUT	EFFICIENCY					
					RPM	Kcal/hr	Watt		Btu/hr	Watt	EER Kcal/Whr	COP W/W		
CKVR452L*	LBP	9.03	1380-4020	2000	299	347	1184	210	1.42	1.65	5.64	Fan	188	
				2500	388	452	1540	268	1.45	1.68	5.74			
				3000	472	549	1871	328	1.44	1.67	5.70			
				3500	542	630	2150	379	1.43	1.66	5.67			
CKVR472L*	LBP	9.82	1380-4020	2000	325	378	1288	230	1.41	1.64	5.60	Fan	188	
				2500	422	491	1674	290	1.46	1.69	5.77			
				3000	513	597	2035	357	1.44	1.67	5.70			
				3500	590	686	2338	415	1.42	1.65	5.63			

CKVHR Series BLDC Compressor											R290			
Models	App	Displ.	COMPRESSOR RUNING SPEED (RPM)	ASHRAE 32 CONDITION									COOLING Type	High (mm)
				Speed	COOLING CAPACITY			INPUT	EFFICIENCY					
					RPM	Kcal/hr	Watt		Btu/hr	Watt	EER Kcal/Whr	COP W/W		
CKVHR200L*	LBP	5.2	1380-4020	2000	151	176	600	104	1.46	1.69	5.77	Fan	175	
				2500	191	222	757	130	1.47	1.71	5.82			
				3000	234	272	928	159	1.47	1.71	5.83			
				3500	277	322	1098	189	1.47	1.70	5.81			
CKVHR222L*	LBP	5.7	1380-4020	2000	166	193	658	114	1.46	1.69	5.77	Fan	188	
				2500	209	243	830	143	1.46	1.70	5.80			
				3000	256	298	1017	174	1.47	1.71	5.84			
				3500	304	353	1204	207	1.47	1.71	5.81			
CKVHR252L*	LBP	6.08	1380-4020	2000	177	206	702	121	1.46	1.70	5.80	Fan	188	
				2500	223	260	885	152	1.47	1.71	5.82			
				3000	274	318	1084	185	1.48	1.72	5.86			
				3500	324	376	1284	222	1.46	1.70	5.78			
CKVHR302L*	LBP	6.79	1380-4020	2000	198	230	784	136	1.45	1.69	5.76	Fan	188	
				2500	249	290	988	170	1.47	1.71	5.81			
				3000	305	355	1211	210	1.45	1.69	5.77			
				3500	362	420	1434	249	1.45	1.69	5.76			
CKVHR352L*	LBP	7.24	1380-4020	2000	211	245	836	145	1.45	1.69	5.76	Fan	188	
				2500	266	309	1054	181	1.47	1.71	5.82			
				3000	326	379	1291	221	1.47	1.71	5.84			
				3500	386	448	1529	263	1.47	1.70	5.81			
CKVHR402L*	LBP	8.37	1380-4020	2000	244	283	966	168	1.45	1.69	5.75	Fan	188	
				2500	307	357	1219	210	1.46	1.70	5.80			
				3000	377	438	1493	256	1.47	1.71	5.83			
				3500	446	518	1767	306	1.46	1.69	5.78			
CKVHR422L*	LBP	9.03	1380-4020	2000	263	306	1042	181	1.45	1.69	5.76	Fan	188	
				2500	332	386	1315	225	1.47	1.71	5.84			
				3000	406	472	1611	275	1.48	1.72	5.86			
				3500	481	559	1907	328	1.47	1.70	5.81			
CKVHR452L*	LBP	9.82	1380-4020	2000	286	332	1133	197	1.45	1.69	5.75	Fan	188	
				2500	361	419	1430	245	1.47	1.71	5.84			
				3000	442	514	1752	298	1.48	1.72	5.88			
				3500	523	608	2074	355	1.47	1.71	5.84			

CKVHR Series BLDC Compressor											R290			
Models	App	Displ.	COMPRESSOR RUNING SPEED (RPM)	ASHRAE 32 CONDITION									COOLING Type	High (mm)
				Speed	COOLING CAPACITY			INPUT	EFFICIENCY					
					RPM	Kcal/hr	Watt		Btu/hr	Watt	EER Kcal/Whr	COP W/W		
CKVHR252M*	MBP	5.2	1380-4020	2000	256	298	1016	157	1.63	1.90	6.48	Fan	188	
				2500	321	373	1272	194	1.65	1.92	6.55			
				3000	385	448	1528	231	1.67	1.94	6.62			
				3500	449	522	1780	269	1.67	1.94	6.62			
CKVHR272M*	MBP	5.7	1380-4020	2000	281	327	1114	170	1.65	1.92	6.55	Fan	188	
				2500	352	409	1394	211	1.67	1.94	6.62			
				3000	422	491	1675	251	1.69	1.96	6.68			
				3500	492	572	1951	292	1.69	1.96	6.68			
CKVHR302M*	MBP	6.08	1380-4020	2000	300	348	1188	180	1.67	1.94	6.62	Fan	188	
				2500	375	436	1487	223	1.69	1.96	6.68			
				3000	450	524	1786	265	1.70	1.98	6.75			
				3500	525	610	2081	308	1.70	1.98	6.75			
CKVHR352M*	MBP	6.79	1380-4020	2000	335	389	1327	199	1.69	1.96	6.68	Fan	188	
				2500	419	487	1661	246	1.70	1.98	6.75			
				3000	503	585	1995	292	1.72	2.00	6.82			
				3500	586	682	2324	341	1.72	2.00	6.82			
CKVHR402M*	MBP	7.24	1380-4020	2000	357	415	1415	210	1.70	1.98	6.75	Fan	188	
				2500	447	519	1771	260	1.72	2.00	6.82			
				3000	536	624	2127	309	1.74	2.02	6.89			
				3500	625	727	2478	360	1.74	2.02	6.89			
CKVHR452M*	MBP	8.37	1380-4020	2000	413	480	1636	240	1.72	2.00	6.82	Fan	188	
				2500	516	600	2047	297	1.74	2.02	6.89			
				3000	620	721	2459	352	1.76	2.05	6.99			
				3500	723	840	2865	410	1.76	2.05	6.99			

MOTOR TYPE & WIRING DIAGRAM

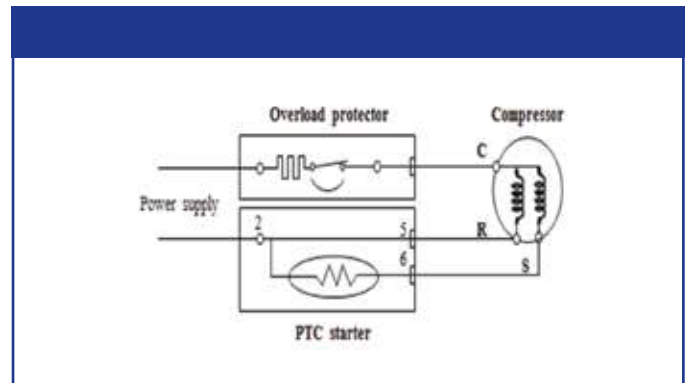
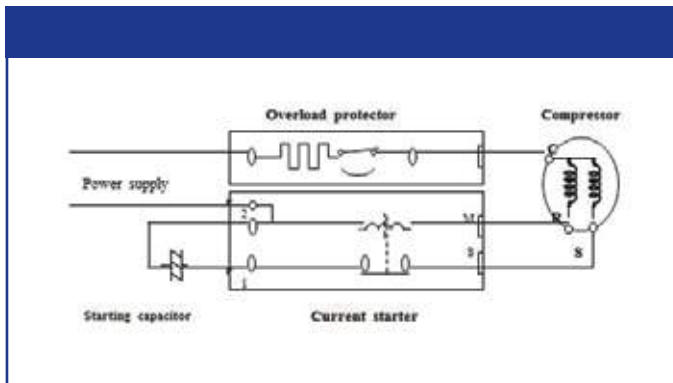

PTC-CSIR

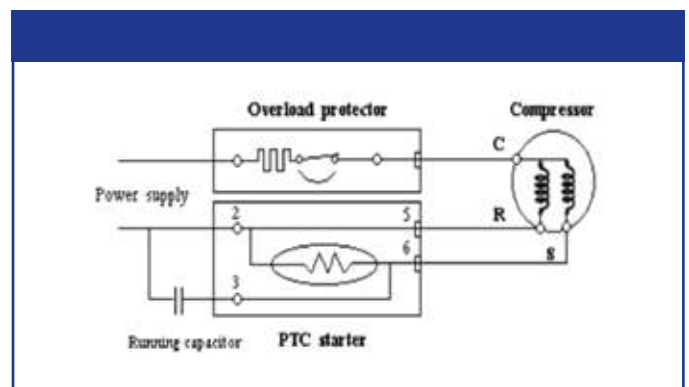
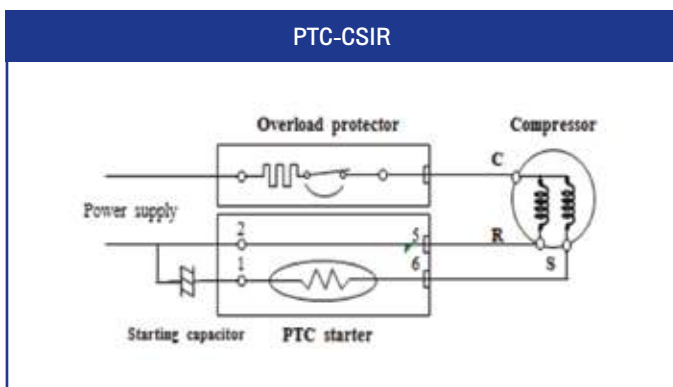

PTC-CSR

